



ENERGY FACTOR MODELING AND MODEL REFERENCE ADAPTIVE CONTROL OF CHAOS IN CUK CONVERTER

R. Manikumar and R. Kayalvizhi

Department of Instrumentation Engineering, Faculty of Engineering and Technology, Annamalai University, Annamalai Nagar, Tamilnadu, India

E-Mail: manikumar.au@gmail.com

ABSTRACT

Chaos is an apparently disordered deterministic behavior, which is universally occurring in many systems in all areas of science. In this paper, chaos in CUK converter has been analyzed by taking the input supply voltage as a bifurcation parameter under open loop condition. The mathematical model of the CUK converter is obtained using Energy Factor modeling approach. A Lyapunov's stability based Model Reference Adaptive Controller (MRAC) is designed for the CUK converter and is implemented to control chaos by keeping the system stable from chaotic stage. The proposed adaptive controller, in the on line mode has the ability to track a specific high-frequency reference voltage and also to adapt for the variations in the load and high-frequency pulsed supply voltage. The simulation results show that the proposed method updates the adjustable parameter values to guarantee stable operation from chaotic stage and also to provide good dynamical responses.

Keywords: CUK converter, model reference adaptive controller, chaos, pulse width modulator, metal oxide semi conductor, field effect transistor, energy factor.

1. INTRODUCTION

The voltage controlled CUK converter has a broad range of applications in power control. There are a lot of cases where electrical energy is processed by power electronics before its final consumption. Because of its wide applications the study of the strange phenomenon such as bifurcation and chaos is very essential. The presents switching elements, nonlinear components (e.g. the power diodes) and control methods (e.g. pulse-width modulation) implies that circuits are nonlinear, time varying dynamical systems. This paper proposes an adaptive feedback method for controlling chaos in CUK converter by keeping the system stable from chaotic stage due to line variations. In practice it is necessary to regulate output voltage against changes in the input voltage and load by adding a feed back control loop. The circuit diagram of the proposed Scheme is shown in Figure-1.

The purpose of this paper is to apply MRAC for controlling the Pulse Width Modulator (PWM) of the switching CUK converters. In this paper, the chaos of the CUK converter operated under open loop is analyzed through bifurcation, by taking the input supply voltage as a bifurcation parameter.

The mathematical model of CUK converter is determined from the Energy Factor (EF) and its relevant parameters. The MRAC designed by Lyapunov's stability theorem is implemented for controlling the chaos of the CUK converter. The dynamical performance of the proposed method is simulated using MATLAB/SIMULINK.

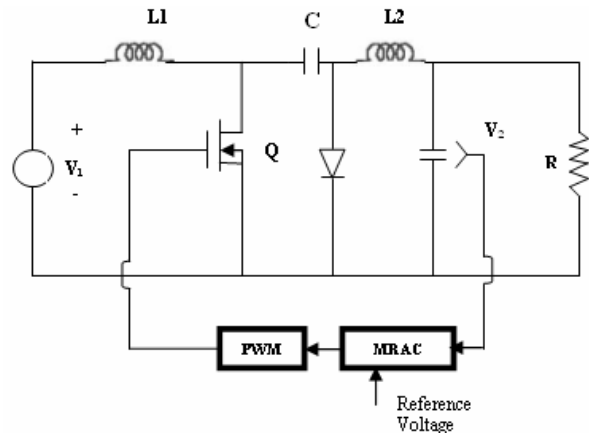

Figure-1. Circuit diagram of proposed scheme.

This paper is organized as follows. Section 2 identifies the occurrence of chaos in CUK converter through bifurcation study under open loop condition. Section 3 provides a description of Energy Factor and Mathematical Modelling of CUK converter. Section 4 details the design and implementation of MRAC using Lyapunov's stability theorem. Section 5 gives the simulation results of the controlled chaos output and the dynamical responses.

2. BIFURCATION ANALYSIS

The simulated results for the various supply voltage leading to chaos are described in this section. The analysis has done under open loop condition.

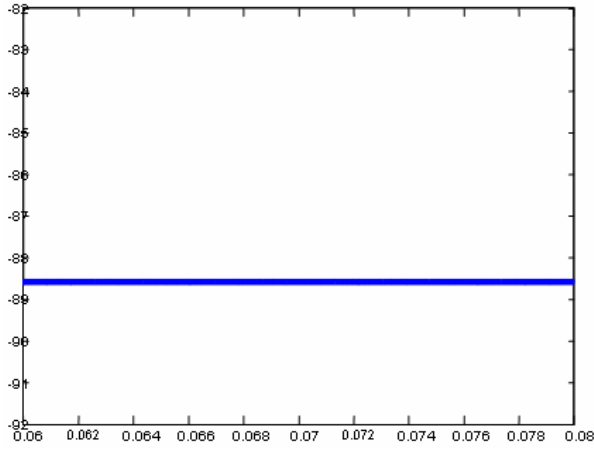

Figure-2. Time domain waveform for supply voltage 100V.

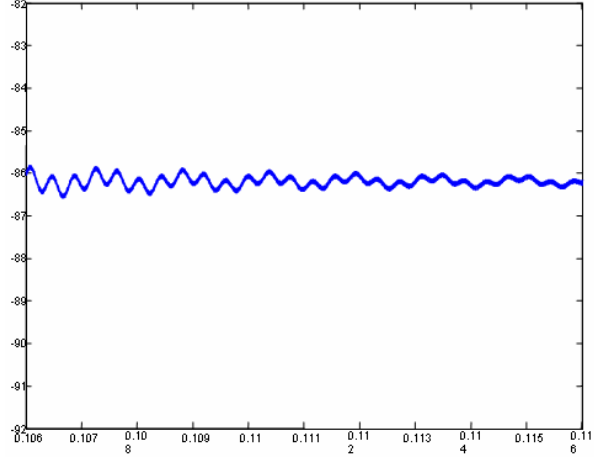

Figure-5. Time domain waveform for supply voltage 70V.

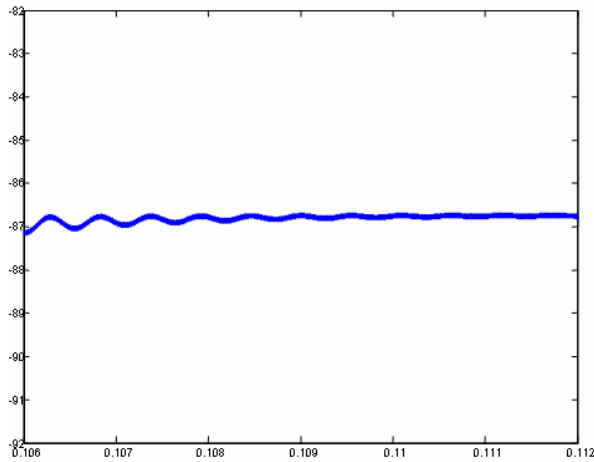

Figure-3. Time domain waveform for supply voltage 90V.

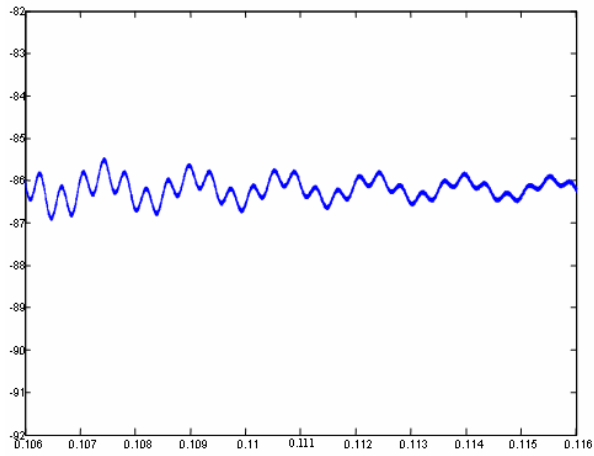

Figure-6. Time domain waveform for supply voltage 60V.

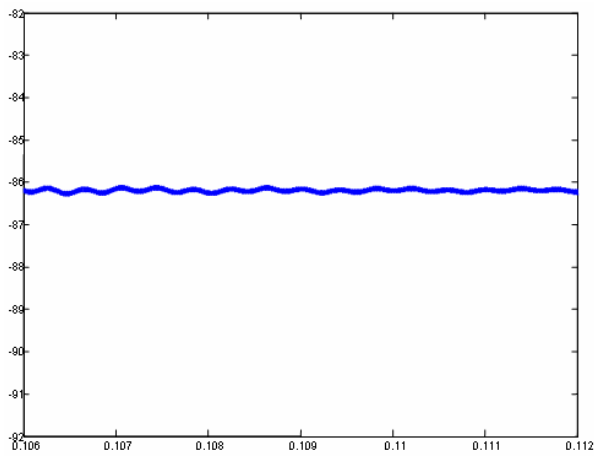

Figure-4. Time domain waveform for supply voltage 80V.

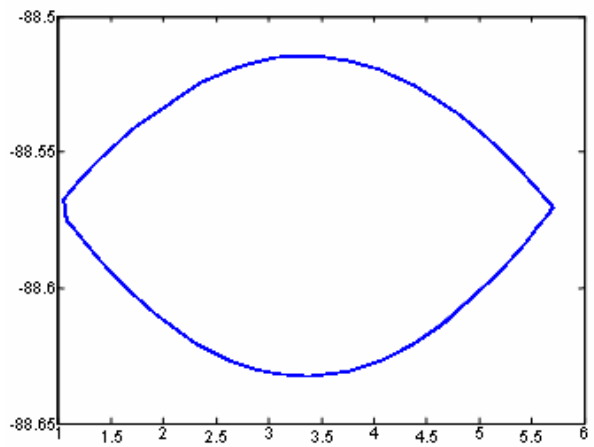

Figure-7. Phase portrait for supply voltage 100V.

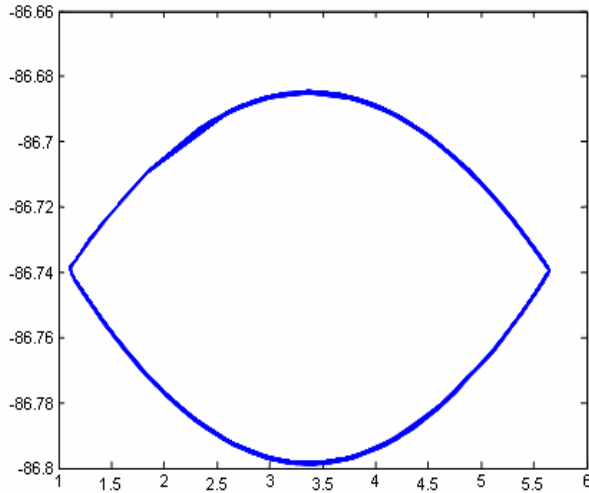

Figure-8. Phase portrait for supply voltage 90V.

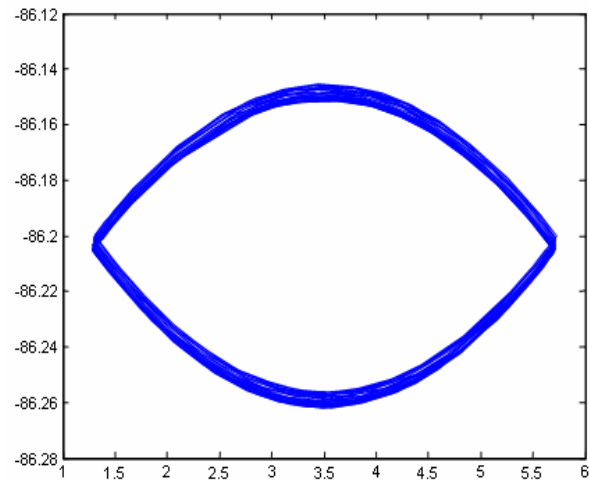

Figure-9. Phase portrait for supply voltage 80V.

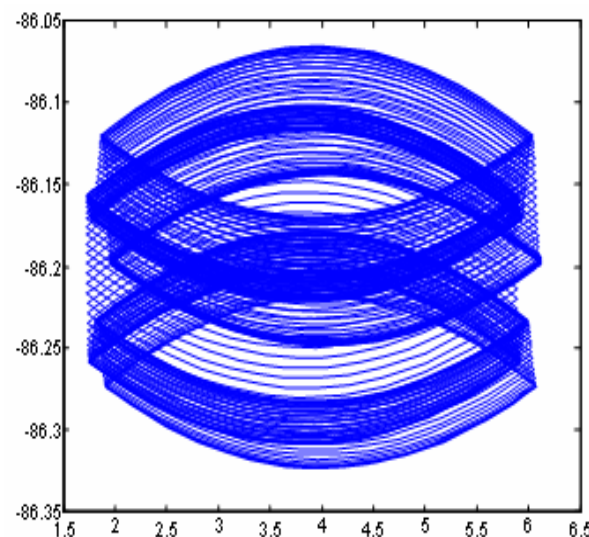

Figure-10. Phase portrait for supply voltage 70V.

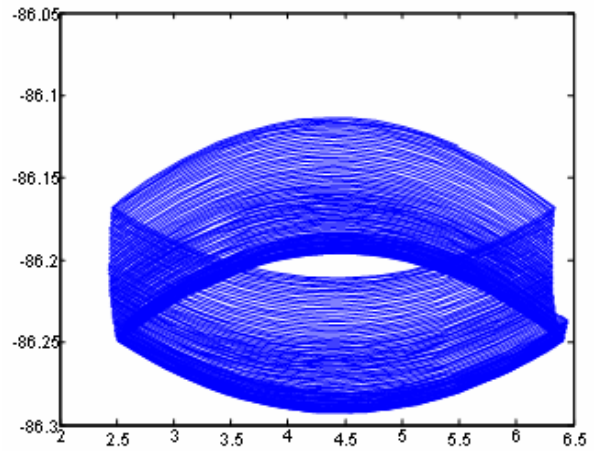

Figure-11. Phase portrait for supply voltage 60V.

Table-1.

Supply voltage (V)	Operation
100V	Stable
90V	Stable
80V	Stable
70V	Chaos
60V	Chaos

The time domain waveform (output voltage Vs time) and the corresponding phase portrait (capacitor Voltage Vs inductor current) is taken for various supply voltage and it clearly gives the stable and chaotic operation of the CUK converter. For certain values of line variations, a strange phenomenon named chaos is observed. Therefore, a new adaptive control scheme for converter is designed to monitor the output loading condition and updates the adjustable parameters and adaptively changes its control parameters to control the chaos as well as to give dynamical performances corresponding to any load and line variations.

3. ENERGY FACTOR AND MATHEMATICAL MODELING

All power DC/DC converters have a pumping circuit to transfer the energy from source to some passive energy storage elements, e.g., inductors and capacitors. The Energy Factor (EF) and its associated parameters comprising the pumping energy (PE), stored energy (SE), capacitor/inductor stored energy ratio (CIR) and energy losses (EL), can illustrate the unit step response which may be helpful for system design and in anticipating DC/DC converter characteristics.

The DC/DC CUK converters are analyzed to demonstrate the application of EF, PE, SE and CIR. The input voltage and current are defined as V_1 and I_1 respectively, and the output voltage and current are defined as V_2 and I_2 , respectively. The switching



frequency, switching time period and duty cycle ratios are defined as f , T and k , respectively.

The energy quantization is measured by the PE, which is used to count the input energy in the switching period (V_1 is usually constant). Its calculation formula is

$$PE = V_1 I_1 T$$

$$\text{The stored energy in an inductor is } W_L = \frac{1}{2} L I_L^2$$

$$\text{The stored energy across a capacitor is } W_C = \frac{1}{2} C V_C^2$$

Therefore, if there are n_L inductors and n_C capacitors, the total stored energy in a DC/DC converter is

$$SE = \sum_{j=1}^{n_L} W_{Lj} + \sum_{j=1}^{n_C} W_{Cj}$$

The capacitor/inductor stored energy ratio (CIR) is

$$CIR = \frac{\sum_{j=1}^{n_C} W_{Cj}}{\sum_{j=1}^{n_L} W_{Lj}}$$

Another factor is the EL in period T , which are proportional to the power losses.

$$EL = P_{\text{loss}} * T$$

The Energy Factor is the ratio of stored energy and pumping energy. Therefore, $EF = \frac{SE}{PE}$

The EF is used to describe the characteristics of power DC/DC converters. Usually, most DC/DC converter analysis assumes that input power is equal to output power, $P_{\text{in}} = P_o$ (or $V_1 I_1 = V_2 I_2$), so that pumping energy is equal to output energy in a period: $PE = V_1 I_1 T = V_2 I_2 T$. It corresponds that the efficiency (η) = $V_2 I_2 T / P.E$.

If the load is purely resistive (R), $V_2 = I_2 R$, and the Voltage transfer gain (M) of DC/DC converter is:

$$M = (V_2 / V_1) = (I_2 R / V_1).$$

And,

$$P_{\text{in}} = P_o + P_{\text{loss}}$$

$$\text{The power transfer efficiency is } \eta = \frac{P_o}{P_{\text{in}}}$$

The time constant of DC/DC converter is defined as:

$$\tau = \frac{2T * EF}{1 + CIR} \left(1 + CIR \frac{1 - \eta}{\eta} \right)$$

The time constant τ is used to estimate the converter transient operation. It is proportional to the process settling time. Since a converter usually consist of multiple passive energy storage elements, for this investigation, the converter response should usually involve an oscillation component.

The damping time constant τ_d of DC/DC converter is defined as:

$$\tau_d = \frac{2T * EF}{1 + CIR \eta} \frac{CIR}{\eta + CIR(1 - \eta)}$$

τ_d is used to estimate the converter response with oscillation. Both τ and τ_d are independent from the switching frequency f and conduction duty cycle ratio k and also available to form the transfer function of the DC/DC converter in S-domain.

The transfer function of the DC/DC converter can be written in mathematical model as:

$$G(S) = \frac{M}{1 + s\tau + s^2\tau\tau_d}$$

The transfer function of the DC/DC converter can be approximated as mathematical model in first order form as:

$$G(S) = \frac{M}{1 + s\tau}$$

To verify the theoretical analysis and the design of previous section, the parameters and specifications of DC/DC CUK converter are taken and are shown in Table-2.

Table-2. Specifications and parameters of CUK converter.

Specification	Value	Circuit parameters	Value
Input voltage	+100V	Inductor, L1	100 μ H
Operating voltage	-87V	Capacitor, C1	100 μ F
Switching frequency	100kHz	Inductor, L2	50 μ H
Load resistance	20 Ω	Capacitor, C2	100 μ F

When the converter changes from one steady state to another, the corresponding stored energy changes. Therefore, there must be a transient process from one steady state to the new steady state. The Energy Factor, its relevant application parameters, voltage transfer gain (M) and time constant (τ) of CUK converter are determined at the operating voltage -87V and for the switching frequency 100kHz and the values are listed in Table-3.

Table-3. Energy factor, relevant parameters, voltage transfer gain and time constant of CUK converter.

Pumping Energy, PE	0.005894
Stored energy, SE	2.24
Capacitor/inductor stored energy, CIR	434.4
Energy losses, EL	0.002548
Energy factor, EF	383
Power efficiency, η	0.5644
Voltage transfer gain, M	0.8454
Time constant, τ	0.001457



The transfer function of the CUK converter in S-domain is found to be:

$$G(S) = \frac{0.8454}{1 + 0.001457s}$$

From the above obtained transfer function model, the proposed controller containing adjustable parameters are implemented for CUK converter by choosing adaptation gain, $\gamma = 0.7$. This proposed controller guarantees closed-loop system stability and a tracking performance for the output voltage for the variations in the line voltage, reference voltage and the load.

4. SYSTEMATIC CONTROLLER DESIGN

This section constructs a Lyapunov’s stability based MRAC for controlling the PWM width of CUK converter. The MRAS control system for CUK converter is shown in Figure-12.

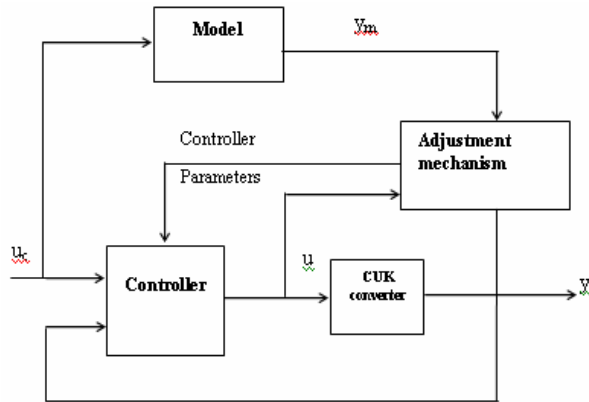

Figure-12. Block diagram of MRAC.

For time-varying systems, the following stability theorem can now be stated. Let $x = 0$ be an equilibrium point for the time-variable differential function of the type

$$\frac{dx}{dt} = f(x,t) \text{ and } D = \{x \in R^n \mid \|x\| < r\}$$

Let V be a continuously differential function such that $\alpha_1(\|x\|) \leq V(x,t) \leq \alpha_2(\|x\|)$

$$\frac{dv}{dt} = \frac{\partial v}{\partial t} + \frac{\partial v}{\partial x} + f(x,t) \leq -\alpha_3(\|x\|) \text{ For } \forall t \geq 0,$$

where α_1, α_2 and α_3 are class k functions. Then $x = 0$ is uniformly asymptotically stable. While using Lyapunov theory for adaptive system, $\frac{dv}{dt}$ is usually negative semi

definite where V is a Lyapunov function. The procedure is to determine the error equation and a Lyapunov function with a bounded second derivative.

For a first order system, the system is described by the plant as $\frac{dy}{dt} = -ay + bu$; Where ‘u’ is the control

variable (i.e., the plant input), ‘y’ is the measured output (i.e., the plant output), ‘a’ and ‘b’ are the plant parameters. The desired response is given by the equation:

$$\frac{dy_m}{dt} = -a_my_m + b_mu_c$$

Where ‘u_c’ is the model input, ‘y_m’ is the model output, ‘a_m’ and ‘b_m’ are the model parameters. Let the controller be $u(t) = \theta_1 u_c(t) - \theta_2 y(t)$. The controller has two parameters θ_1 and θ_2 . If they are chosen to be $\theta_1 = \theta_1^0 = \frac{b_m}{b}$; $\theta_2 = \theta_2^0 = \frac{a_m - a}{b}$ the input-output

relations of the system and model are the same. This is called perfect model following. To apply Lyapunov stability theory, introduce the error as $e = y - y_m$ since, to make the error small, it is natural to derive a differential equation for error.

$$\frac{de}{dt} = -a_me - (b\theta_2 - a_m + a)y + (b\theta_1 - b_m)u_c$$

It is now to construct a parameter adjustment mechanism that will derive the parameters θ_1 and θ_2 to their desired values. For this purpose, assume $b\gamma > 0$ and introduce the following quadratic function.

$$V(e, \theta_1, \theta_2) = \frac{1}{2}(e^2 + \frac{1}{b\gamma}(b\theta_2 + a - a_m)^2 + \frac{1}{b\gamma}(b\theta_1 - b_m)^2)$$

Where ‘ γ ’ is adaptation gain. This function is zero when e is zero and the controller parameters are equal to the correct values. For the function to qualify as a Lyapunov function, the derivative $\frac{dv}{dt}$ must be negative. The

derivative:

$$\frac{dv}{dt} = \frac{1}{2} \left(2e \frac{de}{dt} + \frac{1}{b\gamma} 2(b\theta_2 + a - a_m) b \frac{d\theta_2}{dt} + \frac{1}{b\gamma} 2(b\theta_1 - b_m) b \frac{d\theta_1}{dt} \right)$$

The condition is that $\frac{dv}{dt}$ should be negative semi-definite.

If the parameters are updated as:

$$\frac{d\theta_1}{dt} = -\gamma u_c e \text{ and } \frac{d\theta_2}{dt} = \gamma y e, \text{ then } \frac{dv}{dt} = -a_m e^2$$

The derivative of V with respect to time is thus negative semi definite but not negative definite. This implies that $v(t) \leq v(0)$ and thus that e, θ_1 and θ_2 must be bounded. This implies that $y = e + y_m$ also is bounded.

5. SIMULATED RESULT OF CONTROLLED CHAOS OUTPUT

Simulations have been carried out to verify the chaos controlling idea. A software package: MATLAB Simulink model is used for the simulations. The regulatory response (output voltage Vs time) of the CUK converter for open loop and proposed controller given below shows



the stable result when the supply voltage drops from 100V to 60V for the operating voltage -87V.

The proposed method also shows the chaos coming due to line variation is successfully controlled.

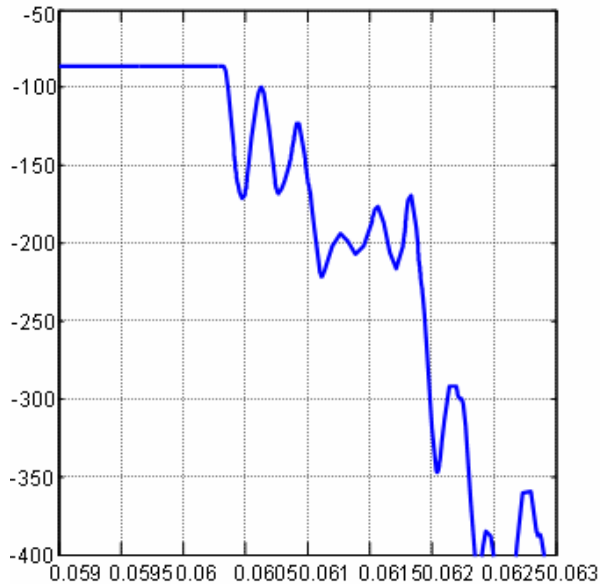

Figure-13. Uncontrolled chaos output at open loop.

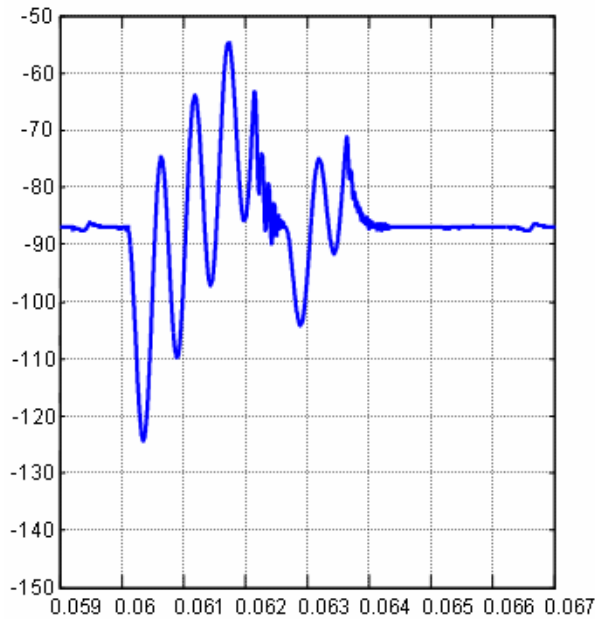

Figure-14. Controlled chaos output for proposed controller.

The proposed scheme also provides good dynamical responses and guarantees closed-loop system stability, a tracking performance for even when there is simultaneous change in high-frequency reference voltage. The simulation results demonstrate the efficiencies of the approach.

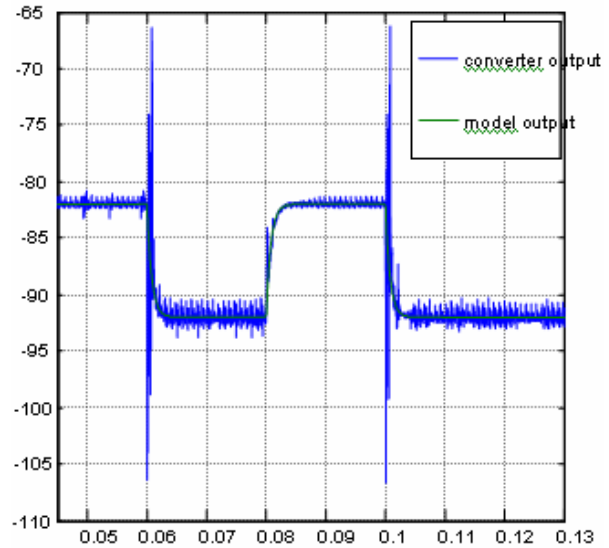

Figure-15. Dynamic behavior of CUK converter for proposed controller.

6. CONCLUSIONS

The voltage controlled CUK converter is taken for the analysis of bifurcation and chaos. The simulated results have been shown for various line voltages and stages leading to chaos are observed for CUK converter. To control such spurious effects in voltage controlled CUK converter, an adaptive method through energy factor modeling has been considered. It is proved that stable operation is possible and chaos has been controlled by keeping the system stable from chaotic stage.

ACKNOWLEDGEMENTS

The authors would like to acknowledge Dr. S. P. Natarajan, Department of Electronics and Instrumentation Engineering, Annamalai University, Annamalai Nagar for granted permission to use the power electronics laboratory.

REFERENCES

- S. Sruthi, A. Kavitha and G. Uma. 2008. Control of Chaos in Buck converter using Adaptive Feedback Sliding Mode Control scheme. Computational Intelligence in Power Apparatus and Systems (CIPS).
- F.L. Luo and H. Ye. 2005. Energy factor and mathematical modelling for power DC/DC converters. IEEE proc., Electr. Power Appl.
- Banerjee. S and G.C. Verghese H. 2001. Nonlinear phenomena in Power Electronics. IEEE Press. Autom control.
- David C. Hamil and David J. Jeffries. 1988. Sub harmonics and chaos in a controlled switched-mode power converter. IEEE Transaction on circuits and systems. 35(8).



www.arpnjournals.com

Arbetter B and Maksimovic. 1997. Feed forward Pulse Width Modulator for Switching Power Converters. IEEE Transactions on Power Electronics. 9(2).

De Keyser R.M.C. 1998. A gentle Introduction to Model Based Predictive control. European Union EC-ALFA-PADI 2 Int. Conference on Control Engineering and Signal Processing, Piura.

Sasaki. S. and T. Inoue. 2000. Systematic approach to robust nonlinear voltage control of buck/boost converter. In: Proc. 31st IEEE Power Electronics Specialists conference.

Karl Johan Astrom and Bjorn Wittenmark. 2006. Adaptive control 2nd Ed., Lund Institute of Technology, Pearson Education.

E. Ott. C. Greobogi and J. A. Yoke. 1990. Controlling chaos. Phys. Rev. Lett. 64: 1196-1199.