



NON-LINEAR BEHAVIOR OF D-TYPE ECCENTRIC STEEL FRAMES

Mazen Ali Musmar

Department of Civil Engineering, Faculty of Engineering, Al-Ahliyya Amman University, Amman, Jordan

E-Mail: mazen.musmar@gmail.com

ABSTRACT

Eccentrically braced frames are used to resist earthquakes as they have the capacity to maintain sufficient stiffness during moderate earthquakes and to absorb and dissipate a large amount of the energy released due to severe earthquakes. The usual steel framing systems; the moment frames require larger member sections to satisfy stiffness requirements and have large ductility capacity, the concentrically braced frames satisfy stiffness on the expense of ductility requirements, resulting in poor energy dissipation. This study deals with the eccentrically Braced Steel Frames (EBF). EBF configuration is similar to traditional braced frames with the exception that at least one end of each brace must be eccentrically connected to the frame. The energy dissipation is achieved through the yielding of a beam segment called the link, while the other frame members, including outer beam segments, braces and columns, should remain essentially elastic. The study incorporates conducting nonlinear finite element analysis to study the effect of the link length and link section on the behavior of D types EBF systems. The study involves material and geometric nonlinearities.

Keywords: D-type eccentrically braced frames, steel frames.

1. INTRODUCTION

Moment Resisting Frames (MRFs) are very common in the construction of single story steel buildings. The MRF has large ductility capacity as compared to other frame types, but the ductility demand on this frame is highly sensitive to the gravity loads that act on its members [1], thus MRF requires larger member sizes to keep lateral deflections with the code mandated limits compared to other frames systems [2].

Roeder and Popov [3] suggested the Eccentrically Braced Frame (EBF) system in which a distance is either created between the two ends of the bracing members, or between the bracing member and the column, or between the bracing member and the beam as shown in Figure-1. The created distance is called link (e).

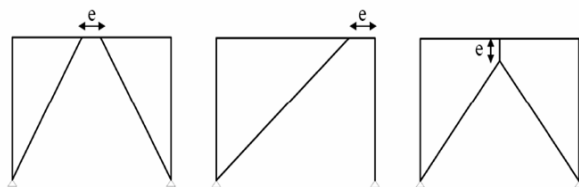

Figure-1. Link in eccentrically braced frame.

The main function of the link is to provide a weak section in the frame which provides plastic deformation capacity and dissipate the energy released by the earthquake.

Concentrically Braced Frames (CBFs) possess high elastic stiffness which results in hampering large drifts and its ability to dissipate energy solely depends on the unstable hysteretic behavior of the braces that may result in loss of lateral stiffness and strength of the frame due to the effect of buckling [4]. According to Mitsumasa *et al.* [5] the building response to a severe earthquake motion can be controlled by increasing the

dissipation energy caused by plastic deformations of energy dissipation members built into a frame structure.

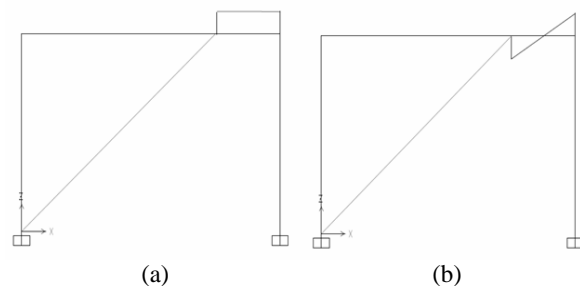

Figure-2. Internal forces along the link in a D-type EBF, (a) shear force diagram, (b) bending moment diagram.

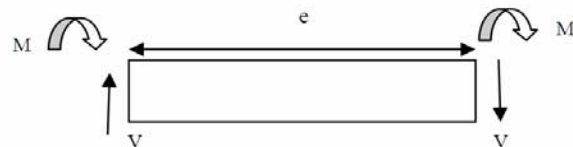

Figure-3. Internal forces acting on the link.

Lee and Bruneau [6] reported that shear yielding in CBFs allow for the development of large plastic deformations without the development of excessive local strains that occur in flexural yielding. Kasai and Popov [7] stated that shear yielding provides a larger energy dissipation capacity than flexural yielding.

Figure-2(a) indicates that the shear force is constant along the whole link length, while Figure-2(b) shows that large bending moments occur only at the ends and that it is a reverse curvature bending.

As illustrated in Figure-2, Figure-3, end moments are close in values and may be approximated as equal. Thus equilibrium of internal forces along the link member yields:



$$e = \frac{2M}{v} \tag{1}$$

Where 2M represents the sum of the internal clockwise end moments, acting on the two ends of the link under double curvature bending. Due to strain hardening in plastic stage, shear link can bear 1.5V_p and 1.2M_p, where V_p and M_p are the plastic shear and the plastic moment of the link, respectively. Substituting the above concept in equation (1) we get, the plastic shear dominates in the link as long as:

$$e = \frac{2 \times 1.2 M_p}{1.5 V_p}, \text{ resulting in } e = \frac{1.6 M_p}{V_p}$$

Thus the plastic shear dominates as long as:

$$e \leq \frac{1.6 M_p}{V_p} \tag{2}$$

This is in accordance with AISC (2006), where links are categorized as:

- Short links, shear links, $e \leq \frac{1.6 M_p}{V_p}$
- Long links, flexural links, $e > \frac{2.6 M_p}{V_p}$
- Intermediate links, $\frac{1.6 M_p}{V_p} < e < \frac{2.6 M_p}{V_p}$

Where

- M_p = Nominal plastic moment capacity, N.mm
- V_p = Nominal plastic shear capacity, N
- E = Link length, mm

The objective of the present work is to study the effect of the link length and link section on the behavior of D-type eccentric bay frames. The study involves material and geometric nonlinearities.

2. FINITE ELEMENT ANALYSIS

ANSYS finite element software is used. Eight single story D-type eccentric bay frames are modeled in addition to a concentrically braced frame. As listed in Table-1 the link length is variable, also two different link sections are adopted, one similar to that of the adjacent beam section and is referred to as the normal section and the other is a reduced section and is referred to as the reduced section. The bracing is so proportioned so as not to buckle at the ultimate strength of the frame.

The frame height is 3m, the bay length is 4m and all input parameters are listed in Table-1. Link is so proportioned that during plastic deformation the web yields before the plastic moment capacity is reached at the link ends. The

required shear strength values given in Table-2 are calculated in accordance with AISC [8] provisions:

- $V_u \leq \phi_v V_n$
- V_n = The nominal shear strength of the link and is equal to the lesser of V_p and 2M_p/e
- e = Link length
- V_p = 0.6F_yA_w; A_w= d*t_w
- ϕ_v = 1

3. MODELING

The physical properties of the steel sections are listed in Table-1. The link sections and lengths and the required shear strength values are given in Table-2.

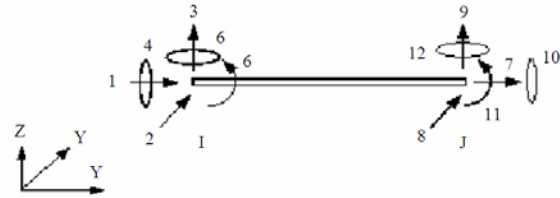

Figure-4. Beam189 element.

Table-1. Properties of the steel sections.

Material model prior to yield surface	Linear elastic
Elastic modulus	200GPa
Poisson's ratio	0.3
Yield stress, f _y	250 MPa
Tangent modulus beyond yield surface	2GPa

Table-2. The parametric dimensions of the model.

	Link type	E (mm)	2M _p /e	V _p (KN)	ϕV _n (KN)
1	W16×36	200	2050	485	514
1b	W10×19		434	228	247
2	W16×36	300	1370	485	514
2b	W10×19		290	228	247
3	W16×36	400	1030	485	514
3b	W10×19		217	228	217
4	W16×36	500	822	485	514
4b	W10×19		174	228	174

Columns section: W16×36, Beam section: W16×36, Bracing: HSS 8×8×1/2

Figure-4 illustrates Beam189 element which is used to model all members of the eccentric frame. It is a quadratic beam element, it is well-suited for linear, large rotation and/or large strain nonlinear applications, elasticity, creep and plasticity models are supported.



Six degrees of freedom exist at each node, these include translations in the x, y and z directions and rotations about the x, y and z directions, the plasticity model is based on Von Mises yielding criteria and it is associated flow rule [9].

4. LOADING AND BOUNDARY CONDITIONS

Primarily Eigen value buckling analysis was used to determine the theoretical buckling load. Such analysis assumes that the structure exhibits linearly elastic behavior, thus the predicted buckling load is overestimated. Based on the predicted load, Nonlinear buckling analysis was carried out. The applied horizontal load was gradually increased, employing non-linear, large-deflection, until a load level was found whereby the structure became unstable. The column supports were assumed to be fixed. The recorded value of lateral displacement was at the beam column joint.

5. DISCUSSIONS

The study was conducted using eight single story D-type eccentric bay frames having dimensions as listed in Table-2, and geometry as shown in Figure-5(a), Figure-6(a).

In frames 1, 2, 3, 4 normal link sections of lengths that varied from 200 mm to 500 mm, with 100 mm increments, are used. In frames 1b, 2b, 3b, 4b reduced link sections with lengths that varied from 200mm to 500 mm are utilized. A ninth D-type braced frame with no shear link, or having $e = 0.0$, is also analyzed to compare the load deflection obtained results.

Figure-5(b) shows that in the case of the normal link section of 500 mm length, the lateral drift at the first yield load is 7.13 mm, and that the lateral drift becomes 18.2 mm just before inelastic buckling load.

Figure-6(b) shows that that in the case of reduced link section of 500 mm length, the lateral drift at the first yield mounts up to 7.4 mm, the lateral drift just before inelastic buckling load becomes 58.2 mm, implying that more ductility is attained.

Also Figure-5(b) shows that in the case of normal link section of 500mm length, the first yield load is 875 KN, which is about 70% of the inelastic buckling load of 1250 KN. Figure-6(b) indicates that in the case of reduced section link, the obtained first yield load value is 575KN, which is about 46% of the inelastic buckling load. The degradation in stiffness in the case of the reduced section link compared to that of the same length normal section link is attributed to the initiation of shear inelastic deformation within the shear link at a lower load step, indicating that inelastic deformations and energy dissipation occur earlier and at a lower load value, resulting in better ductility when using link of reduced section.

Figure-5(d) and Figure-6(d) indicate that in both cases using normal and reduced link sections, the link is subjected to the highest internal shear forces among all frame members. Figure-5(c) shows that maximum bending moments occur at the link ends.

Figures 5(e), 5(f), 6(e), 6(f) illustrate Von Mises stresses for the frame with 500mm link long sections at a load step close to the inelastic buckling load. At this load step, the link internal Von Mises stresses exceed the steel yield stress, while stresses for all other frame members are still below the yield stress. Comparing the values of Von Mises stresses and the amount of inelastic deformation in both normal and reduced sections, it can be concluded that reducing the link section in the D-type Eccentric frame enhances ductility and the ability to dissipate energy, while maintaining tangible stiffness and stability of the frame at severe loadings.

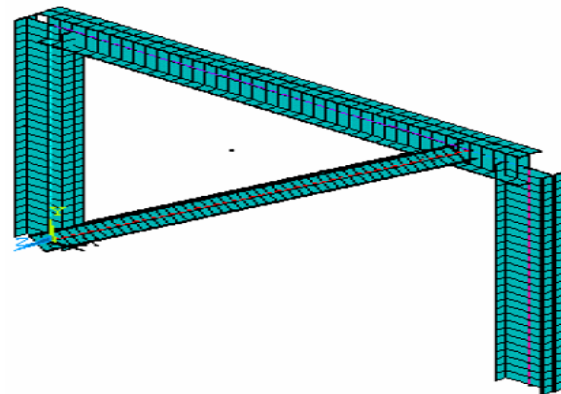

(a)

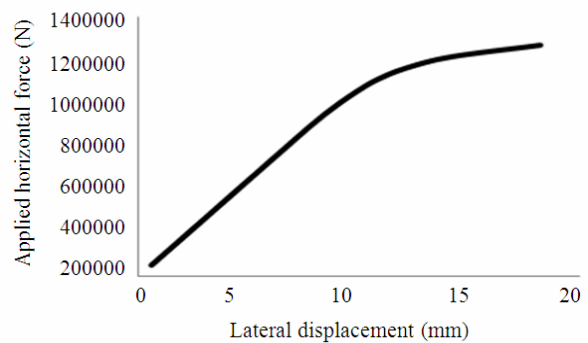

(b)

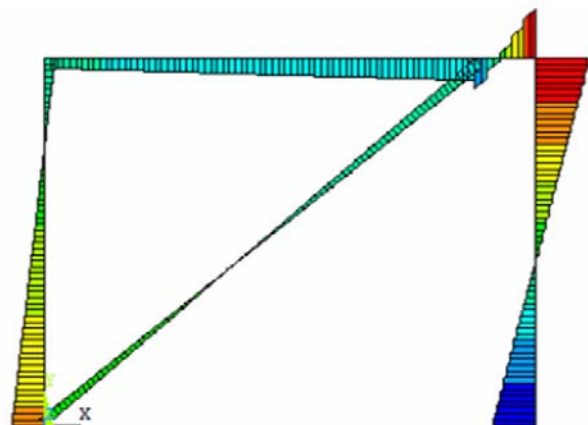

(c)



www.arnjournals.com

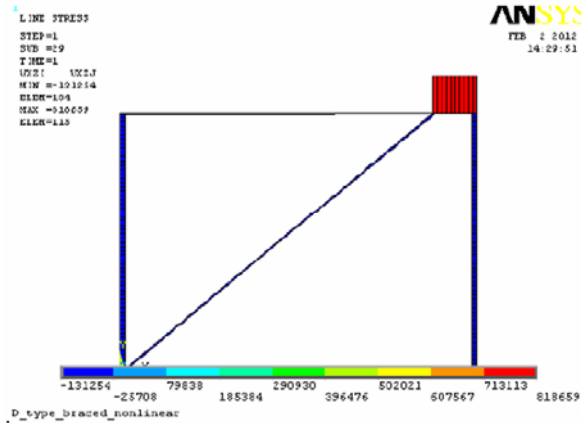

(d)

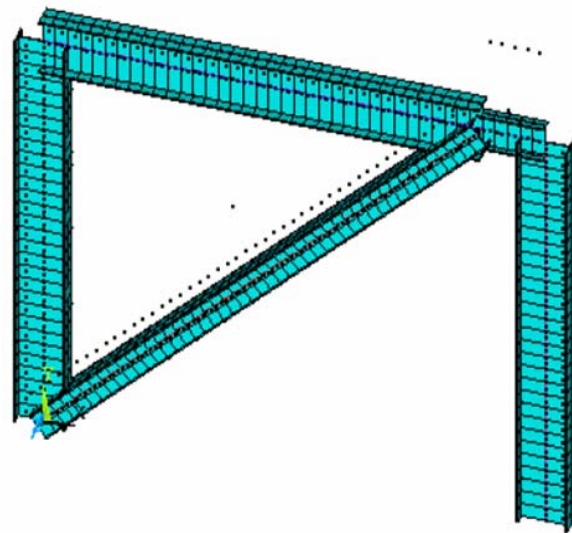

(a)

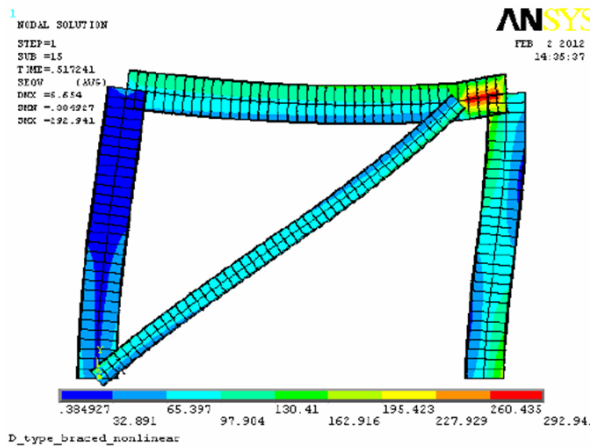

(e)

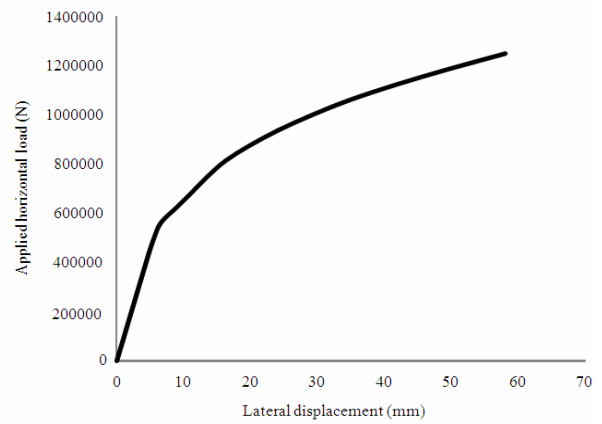

(b)

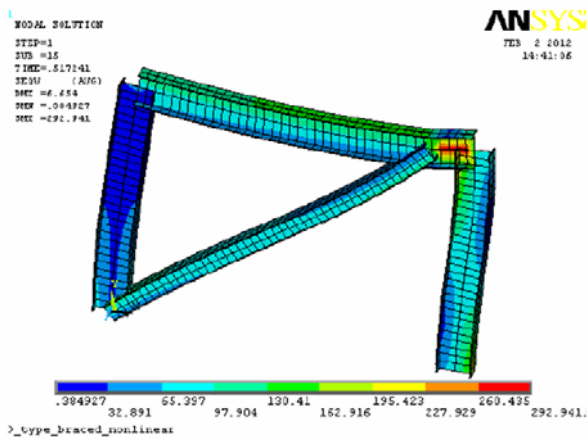

(f)

1
LINE STRESS
STEP=1
SUB =20
TIME=1
MYI MYJ
MIN =-.222E+09
ELEM=147
MAX =.261E+09
ELEM=1

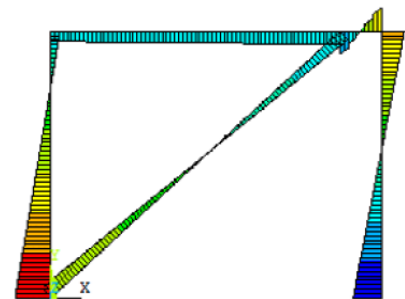

(c)

Figure-5. (a) Isometric view of D-braced frame, (b) Load deflection curve, (c) Bending moment diagram, (d) Shear force diagram, (e) Von Mises stresses, (f) Von Mises stresses isometric view.

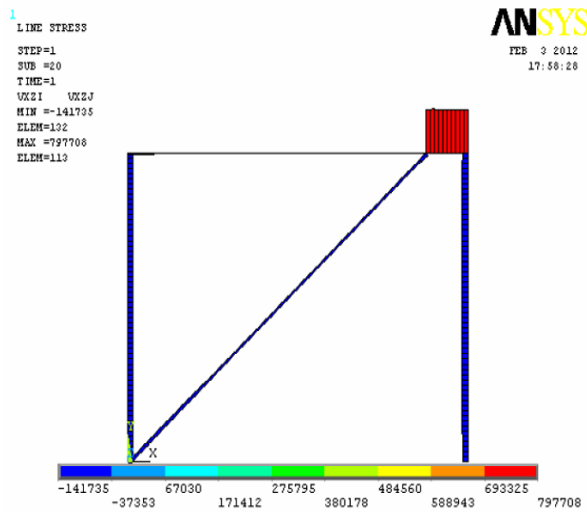

(d)

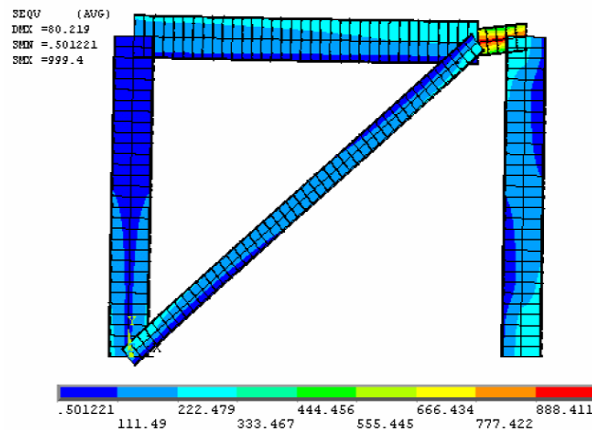

(e)

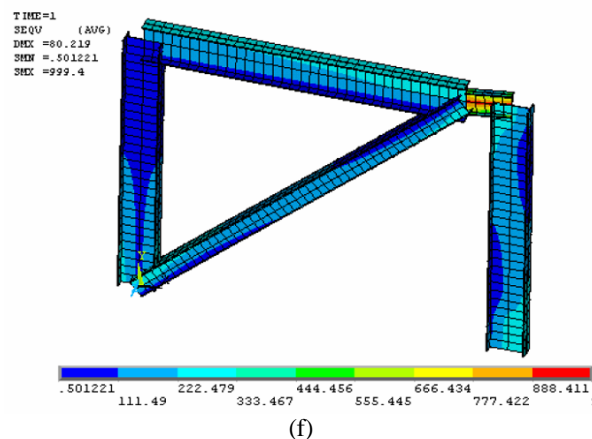

(f)

Figure-6. (a) Isometric view of D-braced frame with reduced link section (b) Load deflection curve (c) Bending moment diagram, (d) Shear force diagram (e) Von Mises stresses (f) Von Mises stresses isometric view.

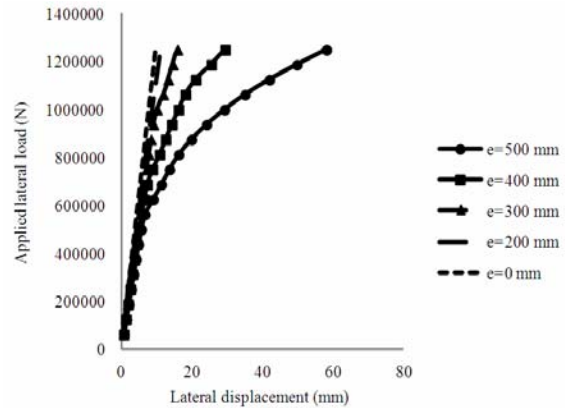

Figure-7. Effect of link length on lateral displacement for several link lengths.

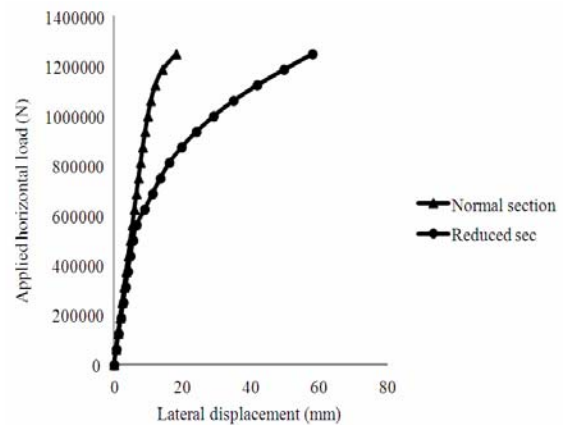

Figure-8. Effect of reduced link section on lateral displacement, link length=500mm.

Figure-7 illustrates the effect of link length on the frame lateral displacement in the case of reduced link section. Shear Link lengths of 200 mm, 300 mm, 400 mm and 500 mm were used as well as concentric braced frame to compare the obtained results. It is noticed that the shorter the shear link is, the stiffer the frame becomes, resulting in remarkable reduction of energy dissipation.

Figure-8 shows that using a reduced link section enhances the ductility and consequently the energy dissipation appreciably.

6. CONCLUSIONS

The study concludes that the behavior of D-type eccentric frames is very much affected by the length and the section of the link.

In an eccentric D-braced frame, short shear links offer better stability and better energy dissipation than long flexural links, because the inelastic deformations occur along the whole link span in the case of shear links, while in flexural links inelastic deformations arise at the link ends.



The shear link is subjected to the highest internal shear forces and bending moments in comparison with the remaining members.

The shorter the shear link is, the stiffer the frame becomes, resulting in remarkable reduction of energy dissipation.

Using reduced link section enhances the D-braced frame ductility and its ability to dissipate energy, while possessing the necessary stiffness that would maintain the stability of the structure at severe loadings.

When links are properly designed, Eccentric D-braced frames may offer high stiffness at working load level and large ductility at severe loadings.

REFERENCES

- [1] Park C.H., D.G. Lee and J.K. Kim. 1997. Effect of gravity load on seismic response of steel-framed structures. *Eng. Struct.* DOI: 10.1016/S0141-0296(96)00108-3. 19: 439-451.
- [2] Bruneau M., C.M. Uang and A. Whittaker. 2011. *Ductile Design of steel Structures*. 2nd Edn. McGraw Hill, New York, ISBN-10: 9780071623957. p. 905.
- [3] Roeder C.W. and E.P. Popov. 1978. Eccentrically braced steel frames for Earthquakes. *J. Struct. Div., ASCE*. 104: 391-412.
- [4] Black G.R., B.A. Wenger and E.P. Popov. 1980. Inelastic buckling of steel struts under cyclic load reversals. Earthquake Engineering Research Center, University of California, Berkely, CA.
- [5] Mitsumasa M., Isao N. and Mitsuru S. 1996. Inelastic behavior of steel frames with steel beam seismic energy dissipation device. *Proceedings of the 11th World Conference on Earthquake Engineering, (WCEE' 96)*.
- [6] Lee K. and M. Bruneau. 2005. Energy dissipation demand of compression members in concentrically braced frames. *Steel Comp. Struct.* 5: 345-358.
- [7] Kasai K. and E.P. Popov. 1986. General behavior of WF steel shear link beams. *J. Struct. Eng, ASCE*.
- [8] AISC. 2006. *Steel construction manual*, ANSI/AISC 341-05. American Institute of steel Construction, Chicago, USA.
- [9] ANSYS. 1998. *Structural analysis guide*. Release. 6: 557-567.