



ON-LINE MONITORING SYSTEM OF WATER LEAKAGE DETECTION IN PIPE NETWORKS WITH ARTIFICIAL INTELLIGENCE

A.Ejah Umraeni Salam¹, Muh.Tola¹, Mary Selintung² and Farouk Maricar²

¹Department of Electrical Engineering, Hasanuddin University, Jl. Perintis Kemerdekaan KM.10, Makassar, Indonesia

²Department of Civil, Engineering, Hasanuddin University, Jl. Perintis Kemerdekaan KM.10, Makassar, Indonesia

E-Mail: ejah.umraeni@yahoo.com

ABSTRACT

This research aims to detect the leakage of pipeline by computerized on-line system using pressure analysis, as a determinant of the leakage in a pipe. At the first stage, the data is obtained from pressure changed at each location of the leakage and taken from the EPANET, a hydraulic modelling system, as simulated data. The simulation data consist of input data, in the form of pressure at each junction, and the output data, in the form of magnitude and location of leakage. Furthermore, the data is processed using one of the Artificial Intelligence methods, The Radial Basis Function Neural Network (RBF-NN), which has two phases: the learning and testing phases. The test results of the method of Radial Basis Function Neural Network are proven to be able to detect the magnitude and the location of leakage with the 98 % accurate prediction result of the whole pipeline system. The next step is creating pressure monitoring equipment on-line to replace the pressure data from the EPANET to the real data, thus the pressure at each junction can be monitored in real time. And by applying the method of RBF-NN, magnitude and location of leakage can be known.

Keywords: leakage of pipelines, EPANET, RBF-NN, monitoring pressure on-line.

INTRODUCTION

The water leakages in distribution pipes is a very important issue that often occurs in many countries in the world. The leakage causes a huge losses. Many methods have been carried out, from manual methods using detection devices to the most current methods using artificial intelligence. The leakage is detected by monitoring the pressure changed in every event of a leakage in pipelines. The development of computerized technology replaced the manual detection of water leakage and the detection can be performed with the help of a computer. The development of Internet network technology is also helpful to on-line monitoring system.

There have been many studies were done related to this problem, such as neural networks in predicting oil pipeline leakage from the pressure sensor data [1] and RBF-NN with differential pressure to detect air leakage [2]. The other research stated the relation between the amount of leakage and the pressure [3]. The similar research used the EPANET, modelling of the water pipe leaks, and the method of SVM to predict the magnitude and location of leakage up to 90 Lt/hour with the distant ranging from 100 to 500 m. It is accomplished by adding a sensor instrument which has the Hybrid Neural Network and Radial Basis Function in determining the amount of water leakage in the distribution network [6]. The research about real-time monitoring water is to improve operational efficiency and using web-based decision support system for supporting integrated water resources management in Daegu city, South Korea [7] [8].

Therefore, based on the previous studies, this research tries to combine detection system of leakage magnitude and location using Radial Basis Function Neural-Network (RBF-NN) method with online monitoring pressure system at each junction pipe in water distribution systems. This research is expected to be used

as a platform for the Regional Water Supply Company as a provider of clean water for the community.

RESEARCH METHOD

Radial Basis Function

The model of artificial neural network of Radial Basis Function is one of a multilayer perceptron, which fixing the weight values, the median value, and the distance between data in order to reduce the errors that occur on the network output. In this model, Neural Networks is using basis activation function in the hidden layer.

Before the Radial Basis Function Neural Network is doing prediction process of leakage location and magnitude at the junction and drain pipes, it is performed the training process. The training process of this method consists of three phases; the entry of input data variable during the training process, setting the value of the spread and neuron/epoch and calculation of error value. The process of setting the spread and epoch value aims to minimize the error.

The steps of Radial Basis Function Neural Network process are:

- a) Loading the input data, in the form of pressure changed, at junction/intersections of pipes or pipelines;
- b) Making the normalization data to obtain the data interval from 0 to 1;
- c) Creating the network initialization to be trained and predicting the future data with some functions in Matlab, NEWRB;

The Process of network training is using the train functions in Matlab applications. The training process is



completed thus the system can learn the patterns of input data and get the performance and percentage of target achievement of location and the best leakage in pipeline.

In this research, the Network structure of Radial Basis Function Neural Network is using three layers; input layer, hidden layer and output layer with 2 neurons. Determination of the number of neurons in the hidden layer is accomplished by trial and error, until getting the smallest error value and the fastest training time. The number of hidden layer neuron is equal to the value of the training epoch. The maximum number of neurons is equal to the number of junctions in the pipeline. Flowchart of System Planning of Radial Basis Function Neural Network can be seen in Figure-1.

METHODOLOGY

The data used in this study is pressure data in each junction/intersection of pipe and obtained at Regional Water Supply Company for region Taman Khayangan Makassar Resident, Indonesia. The data is taken from the pressure data when a leak was happening, either at the junction/intersection point or in a pipeline.

To obtain a model with the accurate prediction results, hundreds to thousands sets of training data are needed. It is not possible to use the actual pipe leak data occurred in the field as the data training. Thus the pressure data is the data obtained from the simulation results using the EPANET 2.0 software. EPANET 2.0 is software for the hydraulic system that has been used by Regional Water Supply Company to monitor pipelines [9].

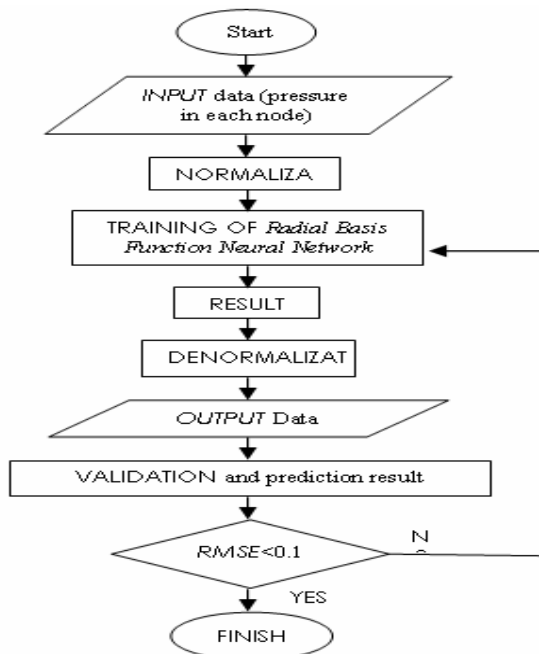

Figure-1. Flowchart of system planning of radial basis function neural network.

The development of piping network system using Epanet 2.0 was completed before doing the leakage simulation. System of piping network constructed by inserting the data in the form of a large flow of water flowing from the reservoir, the length and diameter of the pipe, the level of roughness of each pipe, as well as great of elevation and demand of average water needs in each junction. The data is obtained from the piping network system at Taman Khayangan Makassar Resident.

In general, although EPANET is used for modelling the system of piping network and water quality, the properties of the emitters on the EPANET, designed for modelling the fire hydrants/sprinklers, can be used to model the leakage. The pipeline system of Taman Khayangan Makassar Resident by using EPANET 2.0 software can be seen in Figure-2.

Once the system piping network has been completed, the leakage is simulated using EPANET 2.0 software. The simulation is carried out by changing the emitter coefficient at a junction that will serve as the point of leakage. Emitters are connected to the junction and a model of the flow through the nozzle or orifice that is released into the atmosphere. Function emitters in EPANET are as follows:

$$EC = Q / P^{P \text{ exp}} \quad (1)$$

Where EC is the emitter coefficient, Q is the water discharge, P is the fluid pressure, P exp is pressure exponent. So, coefficient emitter is discharged per unit of pressure with units of liters per second per meter of pressure (Ls^{-1}/m^{-1}). For head nozzle and sprinkler heads P exp is equal with 0.5 [4].

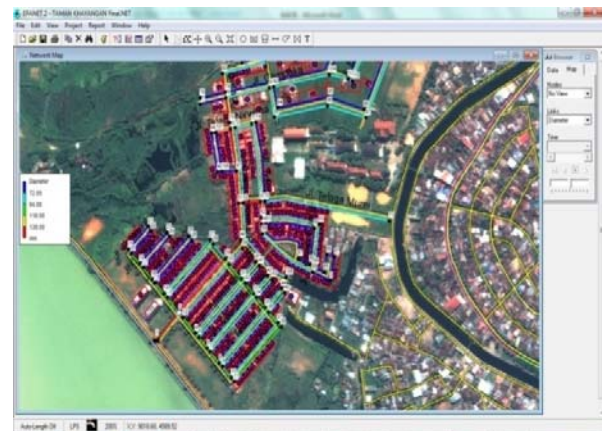

Figure-2. The pipeline system of Taman Khayangan Makassar Resident using EPANET 2.0 software.

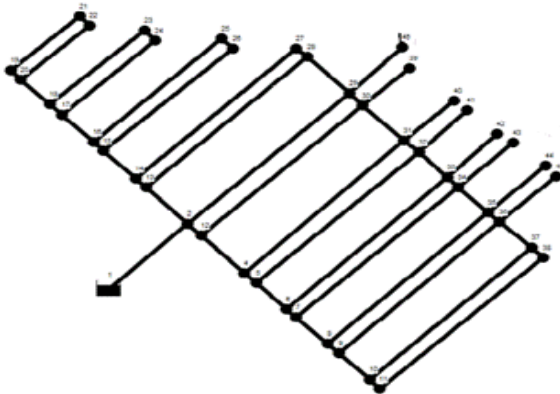

Figure-3. The position of pipe and junction in water distribution network in Taman Khayangan Makassar Resident, Makassar.

The emitter coefficient used for leakage simulation is 0.005 to 0.3 with an interval of 0.005. Amount of average pressure on the pipeline is 3.739158 m. And for 0.005 yield leakage of 0.01 L/s. Total of leakage simulated is achieved between 0.01 to 0.6 L/s. The leakage simulation is performed with 44 sets of case at junction and 623 sets of leakage case in the pipeline with each leak point within 4 meters and an emitter coefficient of 0.005 - 0.3. Therefore, overall there are 40020 of leakage data for various magnitude and position of the leakage. Data layout is used, come from 70 % of data training and 30 % as test data in models RBF-NN.

SIMULATION RESULTS

To detect the leakage magnitude and location by simulation, a model for every pipe should be applied, because the pressure changed on every junction differs on each pipe. The position of the pipe and junction in water distribution network in Taman Khayangan Makassar Resident, Indonesia can be seen in Figure-3.

Training data, in predicting leakage location and magnitude, is input variable data (pressure data on every junction/intersection pipe). While target data is pipe leakage location and magnitude data. Testing stage is accomplished after training stage finished. Using random data of input pressure and the output target, the leakage magnitude and location are 1328 and 1921 as shown respectively in Figures 4 to 5.

The prediction accuracy of leakage location can be expressed with the following formulation :

$$A = \frac{N_p}{N_t} \times 100 \% \tag{2}$$

Where N_p is the amount of success prediction and N_t is the total number of observations.

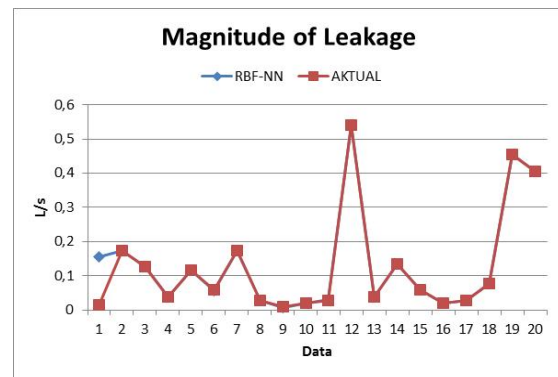
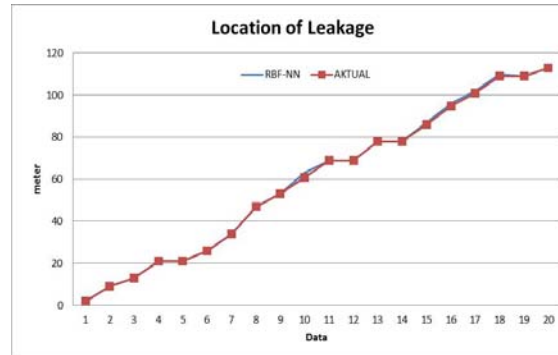

Figure-4. Prediction result and actual target data of pipa 1328.

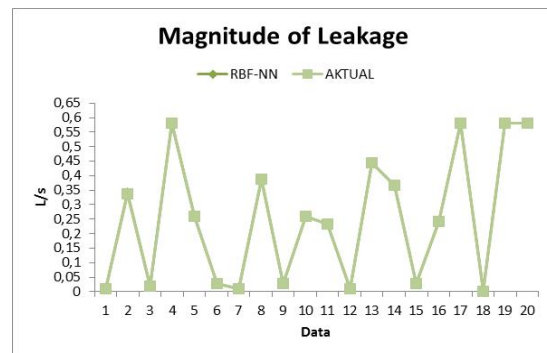
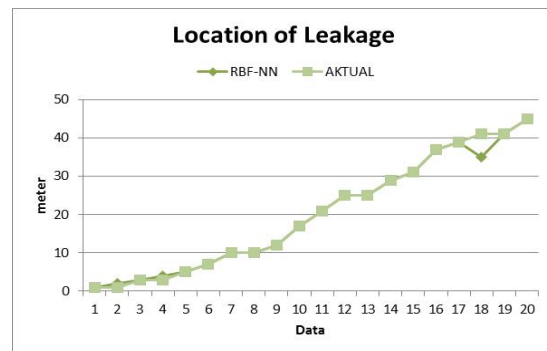

Figure-5. Prediction result and actual target data of pipa 1921.

**Table-1.** The result prediction methods RBF-NN.

Pipe models	Location of Leakage
	Accurate (%)
1328	98
1921	95,94

**Figure-6.** Layout of GUI leak detection system using GUIDE MATLAB.

Table-1 gives the accuracy level of the simulated tests.

Using GUI Interface, user will be easier to use the RBF-NN method in order to detect the leakage. Using the button on the GUI, the user can input the pressure data that will be detected and find the result immediately in the form of a leakage magnitude in L/s and the location of the leakage is depicted on the map location.

The results of making the interface of a pipe leak detection system by using MATLAB R2010a GUIDE can be seen in Figure-6. There are two buttons, the "Input Data", is used to input pressure data in each *junction*, and the "Detection", is to see the predicted results of the leakage magnitude and location. Field "Description" will show the prediction result and on the location map will appear a flashing red dot as the marker of the leakage location

THE DEVELOPMENT MONITORING PRESSURE MEASURING ON-LINE

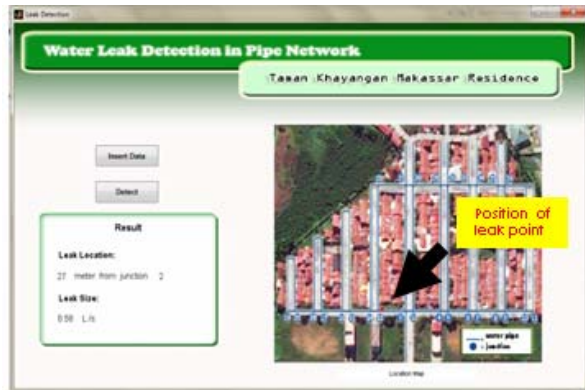
Measurement device of pressure monitoring system is mounted in each junction to replace the simulated data from the EPANET program. Thus, when the pressure has been monitored automatically and it is connected to the RBF-NN method, magnitude and location of the leakage can be identified.

System Hardware

On-line water monitoring system development consists of two stages: hardware development, including microcontroller series, and web development, including website software development. The block diagram of this system is illustrated in Figure-7.

This system utilizes AVR ATmega 328 chip arranged on Arduino UNO microcontroller circuit board as a microcontroller circuit. This system is equipped with PWM facility, serial communication, ADC, timer, interrupt, SPI, and I2C.

This circuit consists of two parts: input circuit comprising MPX5700 pressure sensor and output circuit comprising of the GSM / GPRS Shield and LCD (Liquid Crystal Display). Microcontroller input and output circuit are demonstrated in Figure-8. The function of LCD in this system is to display water pressure measured by the sensor. Pin RS of LCD, which functions as data input for LCD, is connected to pin 12 of the Arduino. The first line of LCD displays indicators, while water pressure (in kPa) is displayed on the second line.

Additional GSM/GPRS Shield device on the Arduino circuit has functions to send data and to enable the Arduino to communicate with the server. The communication, in the form of data packets, is sent on certain intervals and enabled the server to monitor water pressure data. Real time Water Pressure Monitoring device can be seen in Figure-9.

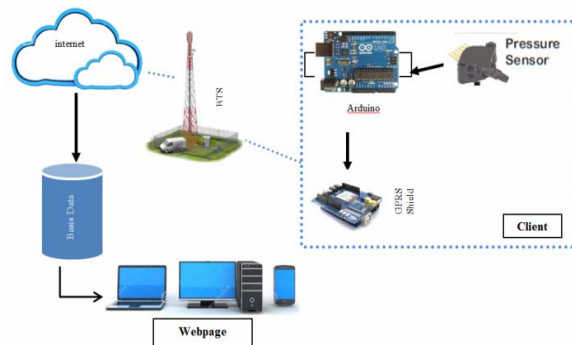
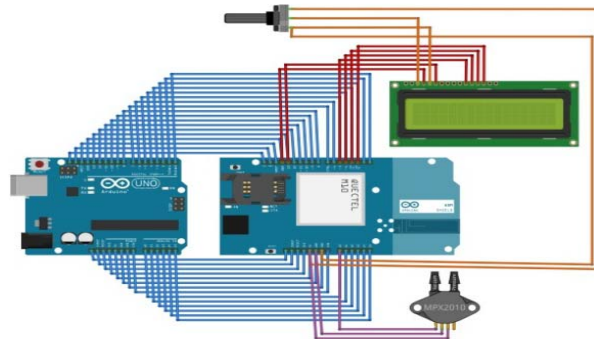
**Figure-7.** System block diagram.**Figure-8.** Microcontroller input and output circuit.

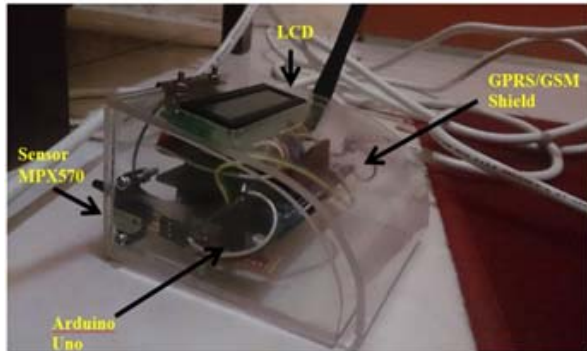

Figure-9. On-line water pressure monitoring device.

Website Software

There are some softwares that must be prepared before starting the programming for the web system monitoring, 1) Adobe Dreamweaver, Aptana Studio 3, Notepad ++ as a software for creating and designing web script; 2) 000webhost.com as a server; 3) PHP, HTML, CSS, Java Script and JQuery as a programming language; 4) MySQL for data storage.

Command lines are written and stored with the extension [*. PHP] and [*. Html] uploaded on 000webhost.com directory that acts as a server, so that command lines that have been written can be compiled by the Web server and web Browser. The web page is used as a container thus the user can interact with the server.

Total evaluation of the device is completed by examining whether the developed device was able to perform real-time water monitoring. This evaluation is done with waterworks pipes as a sample for about 2 hours. The evaluation process is done by attaching the device onto the water works pipe (sample) and parallelizing it with manometer. Data read by MPX5700 sensor is sent to domain halamanreadData.php and stored in the database using script PHP command. Water pressure data are displayed on webpage <http://www.waterpressure.netne.net>. Water pressure measurement results of 20 samples are presented in Table-2.

Based on data obtained from evaluation above, it can be seen that the system operates optimally. The average error percentage of water pressure measurement by the sensor is 1.27%. This result proves the difference between manual measurement and device measurement is the manual measurement in estimating water pressure. However, the time taken to send the data to the server depends on the quality of GSM network used. Measurement Data Layout (as displayed on the webpage) can be seen in Figure-10.

Table-2. Results of device total evaluation.

Manometer (kPa)	LCD (kPa)	Web (kPa)	Send Data Time (s)	PK (%)
27	27	27	71	0
29	28	28	71	3.44
30	29	29	71	3.33
30	30	30	70	0
32	31	31	71	3.125
30	30	30	71	0
31	30	30	70	3.22
31	31	31	73	0
31	31	31	70	0
30	30	30	70	0
30	29	29	71	3.33
30	30	30	70	0
32	31	31	74	3.125
32	33	33	77	3.03
33	33	33	71	0
34	34	34	70	0
34	35	35	71	2.94
35	35	35	71	0
35	35	35	70	0
35	35	35	77	0

No	Pressure(kPa)	Date	Time
1	27	2014-02-19	23:36:29
2	28	2014-02-19	23:37:44
3	27	2014-02-19	23:38:58
4	30	2014-02-19	23:40:01
5	30	2014-02-19	23:41:11
6	30	2014-02-19	23:42:22
7	30	2014-02-19	23:43:32
8	30	2014-02-19	23:44:42
9	30	2014-02-19	23:45:52
10	30	2014-02-19	23:47:04
11	30	2014-02-19	23:48:14
12	30	2014-02-19	23:49:42
13	30	2014-02-19	23:51:54

Figure-10. Measurement data layout (as displayed on the webpage).

CONCLUSIONS

A detection system of magnitude and location of leakage with pressure analysis obtained from the EPANET using the method of Radial Basis Function Neural Network produces the accuracy of the 98% of the entire existing pipeline on the water distribution network. This value indicates that the RBFNN model can detect the magnitude and location of leakage with accurate results.

Furthermore, the manufacture of pressure monitoring devices, where the value of pressure can be



monitored in real-time combined with the computer analysis RBF-NN method is expected to detect on-line magnitude and location of the leakage.

REFERENCES

- [1] Caputo, A.C. and Pelagagge, P.M. 2003. Using neural networks to monitor piping systems. *Process Safety Progress*. 22(2): 119-127.
- [2] Yang Qing, Guo Bin, Lin Min. 2010. Differential pressure prediction in air leak detection using RBF Neural Network. College of Metrology and Measurement Engineering China Ji Liang University Hang Zhou, China.
- [3] Van Zyl J.E. and Clayton C.R.I. 2007. The effect of pressure on leakage in water distribution systems. *J. Water Management*. 160(2): 109-114. (Proc. Inst. of Civ. Eng. UK).
- [4] Mashford J, *et al.* 2009. An approach to leak detection in pipe networks using analysis of monitored pressure values by support vector machine. 2009 Third International Conference on Network and System Security. IEEE Computer Society: 534 -539.
- [5] De Silva D, Mashford J., Burn Stewart. 2011. Computer Aided Leak Location and Sizing in Pipe Network. Urban Water Security Research Alliance Technical Report No. 17.
- [6] Jalalkamali A and Jalalkamali N. 2011. Application of Hybrid Neural Modeling and Radial Basis Function Neural Network to Estimate Leakage Rate in Water Distribution Network. *World Applied Sciences Journal*. 15(3): 407-414.
- [7] Michael A, Ami P, *et al.* 2011. Real-time in network Distribution system monitoring to improve operational efficiency. *Journal Awwa*.
- [8] Yong Z, Yanpeng C, Peng J, Hoogkee J. 2012. Development of a web-based decision support system for supporting integrated water resources management in Daegu city, South Korea. *Expert system with Applications*. 39(11): 10091-10102.
- [9] Rossman Lewis A. 2000. Epanet 2 User Manual Versi Bahasa Indonesia. Water Supply and Water Resources Division National Risk Management Research Laboratory, Cincinnati, OH 45268.