



IMPROVEMENT OF POWER SYSTEM STABILITY USING D-FACTS CONTROLLERS: A REVIEW

P. Sivachandran, T. Hariharan and R. Pushpavathy

Department of Electrical and Electronics Engineering, Sree Sastha Institute of Engineering and Technology, Chennai, India

E-Mail: ssiethodeee@gmail.com

ABSTRACT

As the power demand has been increasing rapidly, power generation and transmission are being affected due to limited resources, environmental restrictions and other losses. Transient stability control plays a vital role in maintaining the steady state operation of power system in the event of huge disturbance, faults and any extinction of power generation. Flexible AC Transmission System (FACTS) controllers were mainly used for solving various power system control problems. This paper presents the study of various FACTS devices and their effects on power system for stability enhancement.

Keywords: FACTS, SSSC, SVC, TCSC, UPFC, IPFC, DPFC, power flow.

INTRODUCTION

A FACTS device is one of the most advance and evolving technology to improve the stability of power transmission system. In the past 1980s, the Electrical Power Research Institute (EPRI) formulates the first vision on the FACTS. The concept of FACTS devices was presented by N.G. Hingorani in 1988 [1] to solve the various power system problems. The excellent effects of semiconductor devices are used to make the FACTS devices which are discussed in below topics. The FACTS devices are mainly used for solving various problems on power transmission system, such as, power flow control, transfer capacity and voltage regulation. The FACTS devices are evolving by two generations. In First generation, FACTS devices employ conventional Thyristor-switched capacitor and reactor, quadrature tap changing transformers such as Static VAR Compensator, Thyristor- Controlled Series Capacitor, and Thyristor - Controlled Phase Shift.

In Second generation, it occupies Gate Turn-Off Thyristor, Thyristor-Switched Converters as Voltage Sources, Converters, such as Static Synchronous Compensator, Static Synchronous series compensator, Unified Power Flow Controller, Integral Power Flow Controller (IPFC), and Distributed Power Flow Controller (DPFC) [2]. From above said various FACTS devices, we are going to focus on D-FACTS device is as follows. The technology of (Distributed- FACTS) D-FACTS devices are recently proposed as an alternative approach for effective functionality of FACTS devices. The D-FACTS device modules have to be clamped on the power transmission line for effective transmission and it is controlling the power flow by increasing or decreasing the impedance of the transmission line. D-FACTS are especially suitable for the development needs of the electric network.

In this paper D-FACTS are used to solve the problems in the power system. The rest of the paper is organized as follows: Section 2 reviews the power system stability Section 3 proposed techniques with suitable examples Section 4 discusses about the FACTS device

types and section 5 discusses the comparison of all FACTS types and conclude in section 6.

POWER SYSTEM STABILITY

In any power system network formation, transmission, and application of electrical power can be segregated into three areas, in which generally resolve the way in which electric utility companies has been organized. Power electronics based equipment is prevailing in each of those three areas, such as with static excitation systems for generation and custom power equipment in the distribution system [3].

CLASSIFICATION OF POWER SYSTEM STABILITY IN POWER SYSTEM NETWORK

The stability is much important for the power transmission system. But various stabilities are there and it depends on various factors of the power transmission system. These stabilities are much more difficult to identify and getting improvement on this. These are complex in nature because we are using lots of different devices and instruments in different range in the system. The following factors considered in classifying the power system stabilities are [4],

- The physical nature of the deriving mode of fluctuation as designate by the main system fluctuate in which fluctuation can be observed.
- The volume of disturbance studied which influences the method of calculation and prediction of stability.
- These devices process and time span that must be taken into deliberation in order to asses' stability.
- The proper way of calculation and prediction of stability. Now will see the different classifications of power system stability.

a) Rotor angle stability

Rotor angle stability means the ability of synchronous machine of an interconnected power system network to persist in synchronism subsequently been subjected to an interruption. It depends upon the capacity



to maintain or restore the equilibrium between mechanical torque and electromagnetic torque of the synchronous machine in the system. The instability of this case occurs because of the increasing angular swing of the generators or the loss of synchronism with other generators [4]. The loss of synchronism in the system happens by the non-equilibrium state between the mechanical torque and electromagnetic torque and the speed difference between the generators.

b) Voltage stability of power system

Voltage stability of power system means the ability of the power system to maintain steady voltage at all the transmission lines in the system after being affected by a disturbance from initial operating condition. This stability depending on to maintain or restore equilibrium between the load demand and supply from the power system [5, 6]. The effect of instability in this case is formed of progressive fall or rise of voltage of transmission lines. The reason for this instability in this loss of load is tripping of transmission lines or other elements and loss of synchronism. And also a run-down situation induces voltage fluctuation occurs. When load dynamic struggle to restore power consumption, apart from the capacity of the transmission network and connected generation [7, 8, 9]. The main circumstances contributing to voltage drop because when the active and reactive power flow through inductive reactance of the system [10]. And this happens when the generators swing their field or armature current time-overload competence limits [11]. There are plenty voltage instabilities are there like voltage drop voltage surge and there like voltage etc., this all can be minimized by maintaining the condition of generators and other devices in good manner [12]. And good operating condition and design of machineries and equipments and skilled operated periodically maintenance [13]. For the best analysis of the voltage stability it has two sub categorized as follows:

i. Large - interruption voltage stability

Large interruption voltage stability assigns to the system's ability to manage steady voltages subsequent large interruption being system faults, loss of generation, or circuit exigency. This ability is resolved by the system and load characteristics, and interactions of both continuous and discrete control protections.

ii. Small - interruption voltage stability

Small interruption voltage stability assigns to the system's ability to maintain steady voltage when subjected to minimum perturbations such as incremental change in system load [14]. This mode of stability is clout by the characteristics of loads, continuous control, and discrete control at a given instant of time.

c) Frequency stability of power system

Frequency stability assign to capability of a power system to manage steady frequency subsequent a severe system disconcerted resulting in a significant

imbalance between generation and load [15]. It depends upon the capability to manage/reinstate equilibrium betwixt system generation and load, with minimum inadvertent loss of load [16]. Fluctuations that may conclusion ensue in the form of uninterrupted frequency swings well-known to trip of generating unit or load [17].

TYPES OF FACTS DEVICES

There are various types of FACTS devices which is having its own attribute and working principle are discussed here in detail, they are static VAR compensator (SVC), and Thyristor controlled series capacitor (TCSC), unified power flow controller (UPFC), Integral power flow controller (IPFC), Static Synchronous series compensator (SSSC), Distributed power flow controller (DPFC) [18, 19].

SVC-STATIC VAR COMPENSATOR

It is connected with the transmission line in parallel connection. It is working as a generator as well as a load for the transmission line [20]. Its output is adjusted to control the various phenomena in the power transmission line for better steady state transmission. It has been connected to the transmission line for controlling several variables [36]. But the primary purpose is quick control of voltage at its weak point of the network. The SVC can connect either mid place or end of the transmission line as we required. Its basic operation is same as synchronous condensers, but without rotating parts. It is working by supplying or absorbing the reactive power from the transmission line. The installation of SVC is shown in Figure-2.

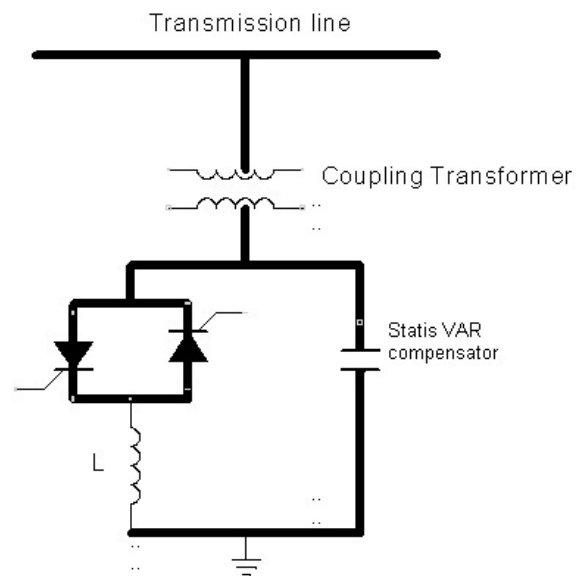

Figure-2. SVC- Static VAR compensator.

It is connected through a coupling transformer with the main AC transmission line whose voltage has to be regulated. SVC is made by the combination of



controllable by controlling the firing angle of Thyristor. It acts as fixed capacitor or fixed inductor at maximum to minimum limits. In the improvement of transient stability through SVC deals with the high performance steady state and transient voltage control compared with classical shunt compensation and this method is analyzed with IEEE 14-bus test system [37].

TCSC-THYRISTOR CONTROLLED SERIES CAPACITOR

It is slightly different from SVC. TCSC is directly connected to the AC transmission line whose capacity of power transmission has to improve [36]. It is connected by series connection with main line. The illustration is shown in Figure-3. Static Voltage Stability Margin Enhancement using TCSC says the combination of TCR and capacitor allows the capacitive reactance to be smoothly controlled according to a specified controlled over a wide range [39]. The main drawbacks in TCSC is not giving high voltage profile when compare to other devices.

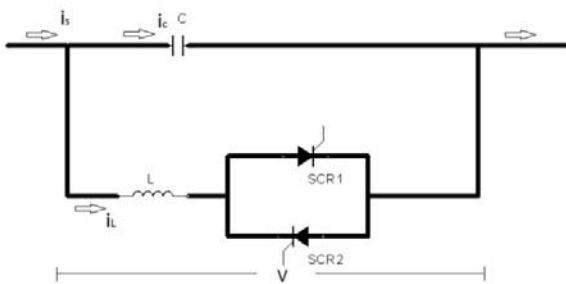

Figure-3. TCSC- Thyristor controlled series capacitor.

SSSC- STATIC SYNCHRONOUS SERIES COMPENSATOR

It has a DC-AC converter and it is connected to a transmission line by series connection through a transformer. It can be act as synchronous voltage source, it can inject sinusoidal voltage of vary and controllable amplitude and series in phase angle. This voltage is relatively quadrature along the line current. The small amount of the injected voltage lies in phase with line current which provides the losses in the inverter. The injected voltage provides the effect of fixing inductive or capacitive reactance in series with the transmission line. The importance is the injected voltage must be quadrature with line current [37, 38]. This capacitive or inductive reactance makes the smooth and steady power flow in the power flow in the power transmission line. The schematic representation of SSSC is shown in Figure-4.

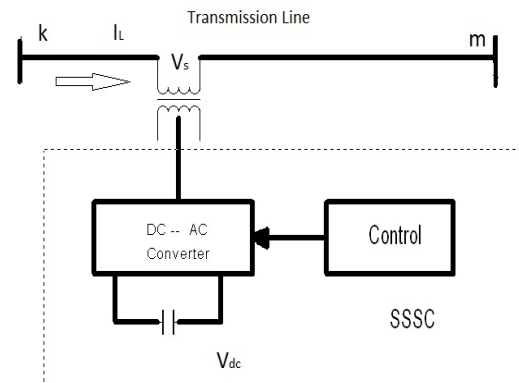

Figure-4. SSSC-Static synchronous series compensator.

It has a DC-AC converter and it is connected to a transmission line by series connection through a transformer. It can be acted as a synchronous voltage source as it can inject a sinusoidal voltage of variable and controllable amplitude and phase angle in the series. This voltage is almost in quadrature with the line current. A small amount of the injected voltage lies in phase with line current which provides the losses in the inverter. The injected voltage provides the effect of fixing an inductive or capacitive reactance in series with the transmission line. The importance is the injected voltage must be quadrature with line current. This capacitive or inductive reactance makes the smooth and steady power flow in the power flow in the power transmission line. The main disadvantage of this device is the voltage acts in opposition to leading quadrature voltage appearing across the transmission-line inductance.

UPFC- UNIFIED POWER FLOW CONTROLLER

Compare with the above discussed FACTS devices. The UPFC has the best effect on efficient steady state transmission. Because of its design and working principle it's having such technology. This technology is settling effect on steady state, dynamic and transient stabilities. The design illustration of UPFC is shown in Figure-5. The major components of UPFC are two AC/DC converters, series and shunt transformer and the capacitor. One AC/DC converter is connected in series along the transmission line over a series. And the other is connected parallel with the transmission line through shunt transformer.

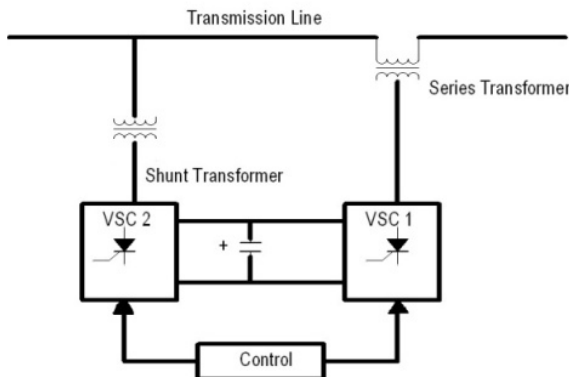

Figure-5. UPFC-unified power flow controller.

The DC output side of the both converters is connected with the capacitor [40] [41]. This capacitor gives DC voltage for the converter operation. Now the entire system of Unified Power Flow Controller is adept of both supplying and absorbing real and reactive power from the system. The power balance between the series and shunt converter is a precondition to retain a constant voltage across the DC capacitor. The power flow capacity and transient stability are improved by series branch of UPFC which inject the voltage of variable magnitude and phase angle. These series branch can exchange real power with a transmission line to improve above said quality of transmission line. The shunt branch of UPFC system is exchanging a current and power factor angle of controllable magnitude with the power system. It is ordinarily controlled to balance the real power absorption or injection into the power system by the series branch, plus the losses by regulating the DC voltage at the desired value.

IPFC- INTEGRAL POWER FLOW CONTROLLER

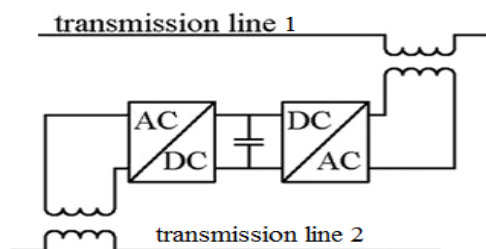

Figure-6. IPFC-integral power flow controller.

The major components used in UPFC devices are shunt transformer, series transformer, and VSC and capacitor bank. The schematic representation of UPFC is shown in Figure-5. Compare with other FACTS devices UPFC is simple in design. The working principle of UPFC is given below. For UPFC the connection between the shunt VSC and series VSC allows active power exchange of the two VSCs so the series VSC can control both the

line active and reactive power flow. The shunt VSC regulates the bus voltage and satisfies the balance of power circulation through the DC capacitor. The operation of GUPFC is similar to a UPFC with the only difference being the GUPFC having multiple series VSCs which can control the power flow on multiple lines. For IPFC two series VSCs connect to each other at the DC bus so one of them (assumed as the Master VSC) can control both line active and reactive power and the other one (assumed as the Slave VSC) can only regulate line active power supporting sufficient active power to the Master VSC through the DC tie.

DPFC- DISTRIBUTED POWER FLOW CONTROLLER

All FACTS devices which we have discussed in above topics are not seen widespread commercial acceptance because of high voltage (up to 345KV), high power (multi-hundred MVA), high cost etc., and [19]. But the concept of D-FACTS devices has recently been proposed as an alternative approach for realizing the functionality of FACTS devices. Here it is proposed to design Distributed Power Flow Controller (DPFC) which is derived from UPFC. UPFC- common DC link=DPFC. Here the absence of a common DC link between the converters increases the reliability of the system. Here active power exchange between series and shunt converter is through the transmission lines at a third harmonic frequency. Here it is proposed to use multiple small size phase converters instead of one large size three phase series converter. The schematic representation of D-FACTS devices is shown in Figure-7.

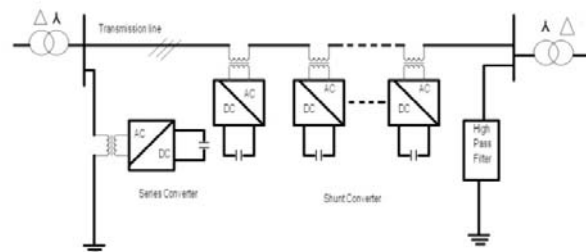

Figure-7. DPFC-distributed power flow controller.

The major components of D-FACTS devices are single turn transformer, single phase voltage source inverter, filter and controlling module, and the self-production module, which is essential for practical implementation [41]. The rating of single D-FACTS devices is about 10 KVA and number D-FACTS devices are clamped on the power line as shown in Figure-7. By increasing or decreasing the impedance of the line, the steady state power flow is achieved. DFC changes its reactance is based on the AVI. The controller makes AB port network to meet the relation between voltage and current of inductance or flux and current of inductance by controlling the inverter [42]. Like this, a port network is



equivalent to the inductance and transformer it can also be controlled as the negative inductance. The value of AVI can be change with the definite value of L. This AVI controlling the impedance of a transmission line accordingly power flow also controlled within the operating constraints of the currents carrying thermal limits of conductors, increase value of transmission assets [43]. With a large number of modules working together, this gives better effects on the overall power flow in the line.

Benefits of utilizing FACTS devices

The benefits of utilizing Flexible AC Transmission System devices in electrical transmission systems can be summarized.

- a) Better utilization of existing transmission system assets.
- b) Increased transmission system reliability and availability.
- c) Increased dynamic and transient grid stability and reduced of loop flows.
- d) Increased quality of supply for sensitive industries.

CONCLUSION AND FUTURE WORK

As we discussed about various problems and instabilities occurring in the power transmission system, they are minimized or removed by using various FACTS devices. And also we have discussed about working principle, special character, design complex, utilization and installation of various FACTS devices. From the above discussion and comparison among various FACTS devices, we can clearly find the technology and concept used in D-FACTS devices can be able to solve the various problems in the power transmission system and can give the effective power transmission. And also the D-FACTS devices using commercially available low power devices offer the potential to dramatically reduce the cost of power flow control. The ability to use nature power conversion techniques demonstrates the potential for high reliability and lower cost implementation. The transient oscillation is more mitigate as the reactance of transmission lines and phase angle. The present work is analyzed with respect to DPFC, various types of FACTS devices are available and can modeled for the transient stability purposed and can be observed the effectiveness of the other FACTS devices during the fault in the power system.

REFERENCES

- [1] N. G. Hingorani and L. Gyugyi. 2000. Understanding FACTS: Concepts and Technology of Flexible AC Transmission Systems. New York: IEEE Press.
- [2] D.J. Hanson, M.L. Woodhouse, C. Horwill. 2002. D.R. Monkhouse and M.M. Osborne. STATCOM: New Era of Reactive compensation. Power Engineering Journal. pp. 151-160.
- [3] R.M. Mathur and R. S. Basati. 2002. Thyristor- Based FACTS Controlled for Electrical Transmission System. IEEE Press Series in Power Engineering.
- [4] P. K. Kundur. 1994. Power System Stability and Control. M.C. Graw Hill, New York, USA.
- [5] Y. Zou, M. H. Yin, and H. D. Chiang. 2003. Theoretical foundation of the controlling UEP method for direct transient-stability analysis of network-preserving power system models. IEEE Trans. Circuits Syst. 50(10): 1324-1336.
- [6] T. Van Cutsem and C. Vournas. 1998. Voltage Stability of Electric Power System. Norwell, MA: Kluwer.
- [7] D. J. Hill. 1993. Non linear dynamic load models with recovery for voltage stability studies. IEEE Trans. Power System. 8: 166-176.
- [8] T. Van Cutsem and R. Mailhot. 1997. Validation of a fast voltage stability analysis method on the Hydro-Quebec System. IEEE Trans. Power System. 12: 282-292.
- [9] T. Van Cutsem and R. Mailhot. 1997. Validation of a fast voltage stability analysis method on the Hydro-Quebec System. IEEE Trans. Power Systems. 12: 282-292.
- [10] J. D. Ainsworth, A. Gavrilovic and H. L. Thanawala. 1980. Static and synchronous compensators for HVDC transmission convertors connected to weak AC system. 28th Session CIGRE, paper 31-01.
- [11] 1992. CIGRE working Group 14.05 Report, Guide for planning DC Links Terminating at AC systems Location Having Low Short-Circuit Capacities Part1: AC/DC Interaction Phenomena, CIGRE Guide No.95.
- [12] 1997. CIGRE Working Group 14.05 Report, Interaction between HVDC convertors and nearby synchronous machine. CIGRE Brochure 119, Oct.
- [13] T. Van Cutsem and R. Mailhot. 2000. Validation of fast voltage stability analysis methods. Proc. IEEE. 88: 208-227.
- [14] D. J. Hill p. a. Lof and G. Anderson. 1990. Analysis of long-term Voltage Stability. Proc. 10th power System computational Conference. pp. 1252-1259.
- [15] P. Kundur. 1981. A survey of utility experiences with power plant response during partial load rejections and system disturbances. IEEE Trans. Power Apparatus and Systems. PAS-100: 2471-2475.



- [16] N. Hatzargyriou, E. Karapidakis and D. Hatzifotis. 1998. Frequency stability of power system in large islands with high wind power penetration. *Bulk Power Syst. Dynamics Control Symp.-IV Restructuring. PAS-102*: Aug. 24-28 Santorini, Greece.
- [17] CIGRE TF 38.03.12 Report. 1997. Power system security assessment: A position paper. *ELECTRA*, no. 175.
- [18] T. E. Dy Liacco. 1968. Control of Power Systems via the Multilevel Concept. Case Western Reserve Univ., Syst. Res. Center, Rep. SRC-68-19.
- [19] T. Van Cutsem. 2000. Voltage instability: phenomena, Counter measures, and analysis methods. *Proc. IEEE*. 88(2): 208-227.
- [20] N. K. Sharma, A. Ghosh and R. K. Verma. 2003. A Novel Placement Strategy for FACTS Controllers. *IEEE Trans. on Power Delivery*. 18(3).
- [21] O. O. Obadina and G. J. Berg. 1990. Identifying Electrically Weak and Strong Segments of Power Systems from Voltage Stability Viewpoint. *IEE Proc. Pt. C*. 137(3): 205-212.
- [22] L. A. S. Pilotto, W. W. Ping, A. R. Carvalho, W.F. Long, F. L. Alvarado, C. L. Demarco and A. Edris. 1997. Coordinated Design of FACTS Controllers to Enhance Power System Dynamic Performance. *International Colloquium on HVDC and FACTS, Johannesburg*.
- [23] S. N. Singh and A. K. David. 2000. Placement of FACTS Devices in Open Power Market. *Proceeding of the 5th International Conference on Advance in Power System Control, Operation and Management, APSCOM 2000, Hong Kong*. pp. 173-177.
- [24] S. N. Singh and A. K. David. 2001. A new approach for placement of FACTS Devices in Open Power Market. *IEEE Power Engg. Rev.* 21(9): 58-60.
- [25] M. K. Verma and S. C. Srivastava. 2005. Optimal Placement of SVC for Static and Dynamic Voltage Security Enhancement. *International Journal of Emerging Electric Power Systems*. 2(2).
- [26] Fadela Benzergua, Abd-el-Kader Chaker, Mounir Khiat and Naima Khalfallah. 2007. Optimal Placement of Static VAR Compensator in Algerian Network. *Information Technology Journal*. 6(7): 1095-1099.
- [27] Srekanth Reddy Donapati and M. K. Verma. 2008. An Approach for Optimal Placement of UPFC to enhance Voltage Stability Margin under Contingencies. *Fifteenth National Power Systems Conference (NPSC), IIT Bombay*. pp. 441-446.
- [28] V. Ajarapu, Ping Lin Lau and S. Battula. 1994. An Optimal Reactive Power Planning Strategy Against Voltage Collapse. *IEEE Trans on Power Systems*. 9(2).
- [29] C. P. Gupta. 2000. Voltage Stability Margin Enhancement using FACTS controllers. Ph. D. Thesis, IIT Kanpur.
- [30] Naoto Yorino, E. E. El-Araby, Hiroshi Sasaki and Shigemi Harada. 2003. A new Formulation for FACTS Allocation for Security Enhancement against Voltage Collapse. *IEEE Trans. On Power Systems*. 18(1).
- [31] Ashwani Kumar Sharma. 2006. Optimal Number and Location of TCSC and Load ability Enhancement in Deregulated Electricity Markets Using MINLP. *International Journal of Emerging Electric Power Systems*. 5(1).
- [32] C. S. Chang and J. S. Huang. 1997. Optimal SVC Placement for Voltage Stability Reinforcements. *Electric Power System Research*. 42: 165-172.
- [33] Tina Orfanogianni, and Rainer Bacher. 2003. Steady-State Optimization in Power Systems with Series FACTS Devices. *IEEE Trans on Power Systems*. 18(1).
- [34] Mohd Wazir Mustafa, and Wong Yan Chiew. 2008. Optimal Placement of Static VAR Compensator Using Genetic Algorithms. *Elektrika*. 10(1): 26-31.
- [35] H. I. Shaheen, G. I. Rashed, and S.J. Cheng. 2008. Optimal Location and Parameters Setting of UPFC based on GA and PSO for Enhancing Power System Security under Single Contingencies. *Power and Energy Society General Meeting-Conversion and delivery of Electrical Energy in the 21st Century, 2008, IEEE*. 20-24 July, pp. 1-8.
- [36] A Sode-Yome, N. Mithulananthan, Kwang Y. Lee. 2007. A comprehensive Comparison of FACTS Devices for Enhancing Static Voltage Stability. 1-4244-1298-6/07, IEEE.
- [37] D. Murali, Dr. M. Rajaram, N. Reka. 2010. Comparison of FACTS Devices for Power System Stability Enhancement "International Journal of Computer Application (0975-8887)". 8(4).
- [38] Mehrdad Ahmadi Kamarposhti, Mustafa Alinezhad, Hamid Lesani, Nemat Talebi. Comparison of SVC, STATCOM, TCSC, and UPFC Controllers for Static Voltage Stability Evaluated by Continuation Power



Flow Method. 978-1-4244-2895-3/2008 IEEE
Electrical Power and Energy Conference.

- [39] M. Arun Bhaskar, C. Subramani, Jagdeesh Kumar, Dr. S.S. Dash. 2009. Voltage Profile Improvement Using FACTS Devices: A Comparison between SVC, TCSC and TCPST. 2009 International Conference on Advances in Recent Technologies in Communication and Computing. 978-0-7695-3845-7, IEEE.
- [40] Ch. Rambabu, Dr. Y. P. Obulesu, Dr. Ch. Saibabu. 2001. Improvement of Voltage Profile and Reduce Power System Losses by using Multi Type Facts Devices. International Journal of Computer Applications (0975 - 8887). 13(2).
- [41] Alok Kumar Mohanty, Amar Kumar Barik. Power System Stability Improvement Using FACTS Devices. International Journal of Modern Engineering Research (IJMER). 1(2): 666-672 ISSN: 2249-6645.
- [42] N. G. Hingorani and L. Gyugyi. 2000. Understanding FACTS: Concepts and Technology of Flexible AC Transmission Systems. New York: IEEE Press.
- [43] 1995. Cigre 95 TP108, FACTS Overview, IEEE Power Engineering Society.
- [44] Banakar Basavaraj, Ronad Basangouda, Jangamshetti Suresh. H. 2012. Transmission Loss Minimization using UPFC. International Journal of Modern Engineering Research (IJMER). 2(5): 3602-3606 ISSN: 2249-6645.