



www.arpnjournals.com

A FUZZY LOGIC BASED ENERGY MANAGEMENT SYSTEM FOR A MICROGRID

S. D. Saranya¹, S. Sathyamoorthi² and R. Gandhiraj¹

¹Department of Electrical and Electronics Engineering, University College of Engineering, Anna University, BIT Campus, Tiruchirapalli, India

²Department of Electrical and Electronics Engineering, Pandian Saraswathi Yadav Engineering College, Sivagangai, India
E-Mail: saranya.9339@gmail.com

ABSTRACT

This paper proposes an approach for the hybrid solar photovoltaic and wind power system in Battery management for stand-alone applications. Battery charging process is non-linear, time-varying with a considerable time delay so it is difficult to achieve the best energy management performance by using traditional control approaches. A fuzzy control strategy for battery charging or discharging used in a renewable power generation system is analyzed in the paper. To improve the life cycle of the battery, fuzzy control manages the desired state of charge (SOC). A fuzzy logic-based controller to be used for the Battery SOC control of the designed hybrid system is proposed and compared with a classical PI controller for the performance validation. The entire designed system is modelled and simulated using MATLAB/Simulink Environment.

Keywords: microgrid, battery management, Fuzzy logic control, state of charge.

1. INTRODUCTION

Many Countries count on coal, oil and natural gas to supply most of their energy needs due to tremendous increase in population growth rate. Fossil fuels are a finite resource. Fossil fuels also cause air, water and soil pollution, and produce greenhouse gases that contribute to global warming. With increased awareness of the depletion of traditional energy sources and environmental damage caused by increased carbon dioxide emissions from coal-fired power generation, the use of renewable energy has become the goal for energy development. Hybrid power generation systems that combine different renewable energy sources and energy storage systems offer an environmentally friendly alternative for standalone operations. However, there are several challenges for the hybrid power system. Appropriate control and coordination strategies among various elements of the hybrid system are required so it can deliver required power.

Due to the nature of intermittence of renewable energy, the use of the secondary energy storage such as batteries become inevitable which will compensate the fluctuations of power generation? First, the renewable resource such as wind or tidal energy is used to drive a turbine, translating its power to mechanical form, which then drives a generator. The AC power generated is generally with a variable frequency and unstable voltage so it will be converted to DC power.

The DC power either is used to serve the load directly or converted to good quality AC power supply to AC loads. Due to uncertainties of the renewable energy availability, battery storage is adopted. So the electricity energy will be saved to the battery when the excessive electricity is generated and the stored energy will supply electricity to the load while there is no enough electrical

power being generated. As we know, frequent charging and discharging will shorten the life time of a battery.

With such a system, the problem is how to determine when the battery should be charged to provide the best energy efficiency and to prolong the life time. The proposed fuzzy control is to optimize energy distribution and to set up battery state of charge (SOC) parameters. A control strategy based on fuzzy control theory has been proposed to achieve the optimal results of the battery charging and discharging performance, and compared with a classical PI controller for performance validation.

2. SYSTEM DESCRIPTION

The Hybrid System is made up of solar photovoltaic array, wind turbine generator, controller with the combination of fuzzy, storage batteries, Rectifier, chopper, inverter, etc. as shown in Figure-1.

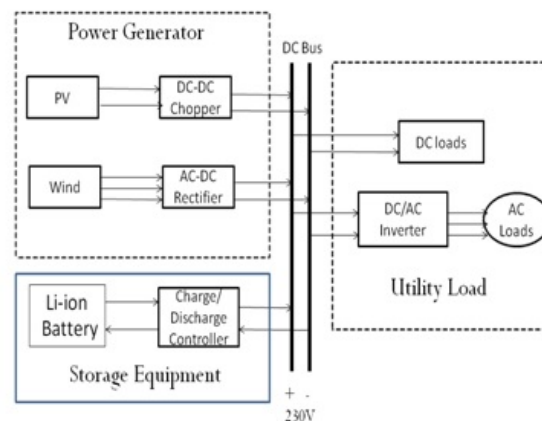

Figure-1. Configuration of the Hybrid System.



Rectifier used in wind Turbine line is to convert AC into DC. Chopper used in Solar PV line is to convert variable DC into constant DC. The DC Bus is connected to batteries through charge controller. Here battery will ensure reliability of the power system for all climatic conditions. Batteries will charge when the power generation from wind and solar PV system is in excess and it will discharge when the power generation from wind and solar PV is not enough to meet the load demand. As shown in Fig. 1, the system configuration includes three major blocks: power generator, energy storage equipment, utility load. The power generator typically includes PV panels, wind turbines. Maximum power point trackers are associated with PV panels and wind turbines to draw maximum power, which is fed into the dc bus. In the system, the output electrical power is provided to the loads with the highest priority. If the output electrical power is excessive for the demands of the loads, the surplus is used to charge the battery. Provided that the loads can't use up the whole output power, and the battery is fully charged, the superfluous power is then sent to the local distribution network if it exists. The battery works in three cases: disconnected from the system, charged by the system or discharge the supply power to the loads

3. SYSTEM MODEL

To verify the accuracy of the designed controller, a dynamic model of the proposed system is necessary. It is basically done by distributed energy and energy storage components were mainly built by MATLAB simulink mathematical modules, based on equivalent circuits of the components. The model of each subsystem is explained in detailed manner below.

A. Modelling of solar cell

The equivalent circuit of solar cell, composed of photo-generated current source, internal series resistance and parallel resistance, is shown in Figure-2.

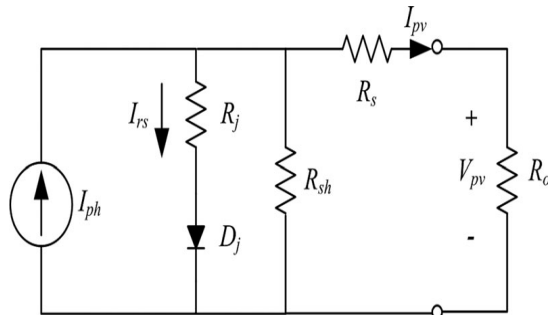

Figure-2. Solar panel equivalent circuit.

Solar panel current equation can be expressed by,

$$I_{PV} = (n_p I_{ph} - n_p I_{rs}) \left[e^{\frac{qV_{PV}}{AKTn_s}} - 1 \right] \tag{1}$$

where V_{pv} is output voltage of solar panels, I_{pv} is output current of solar panels, n_s is number of solar panels in series, n_p is number of solar panels in parallel, k is the Boltzmann constant (1.38×10^{-23} J/K), q is electron charge (1.6×10^{-19} C), A is ideality factor (1-2). T is surface temperature of the solar panels (K), and I_{rs} is reverse saturation current. In equation (1), the characteristic of reverse saturation current I_{rs} varies with temperature, as expressed by equation (2),

$$I_{rs} = I_{rr} \left(\frac{T}{T_r} \right)^3 e^{-\left(\frac{E_g}{kT} \left(\frac{T}{T_r} - 1 \right) \right)} \tag{2}$$

Where T_r is the reference temperature of the solar panels (K), I_{rr} is reverse saturation current of the solar panels at temperature T_r (K), and E_g is energy band gap of the semiconductor material. Equation (3) describes the Photo current depends on solar radiation and cell temperature.

$$I_{ph} = [I_{scr} + K_t(T - T_r)] \left(\frac{G}{G_r} \right) \tag{3}$$

Where I_{scr} is the short-circuit current at reference temperature T_r and illumination intensity 1 kW/m^2 , α is the short-circuit current temperature coefficient of the solar panels.

The Solar panel has been developed by combination of several solar modules, each with a power rating of 180 W, as the photovoltaic device of the hybrid system. For demonstration a solar 5 kW power system, generated by two photovoltaic arrays in parallel, where each array was built with 14 solar panels in series are considered. Dynamic models for the main components in the proposed hybrid system have been developed in MATLAB/Simulink platform. The developed model is utilized for investigate the system performance of intelligent power management strategy and it is shown in Figure-3.

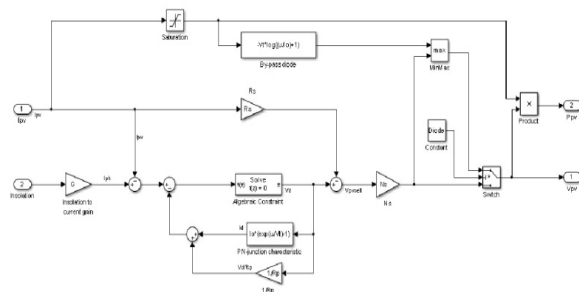

Figure-3. Simulink model of PV cell.

The simulated output power versus output voltage of the solar cell is shown in Figure-4.

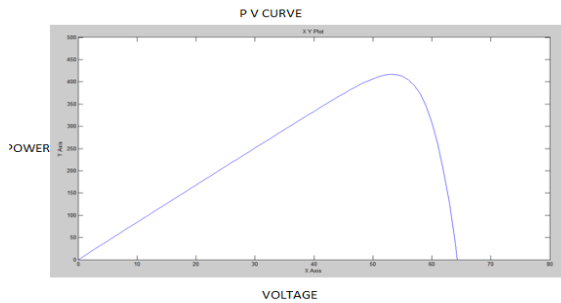

Figure-4. Simulated output power P_{PV} versus output voltage V_{PV} of the solar cell with constant illumination intensity 1 kW/m^2 .

This study used constant illumination intensity 1 kW/m^2 and constant temperature with varying V_{pv} for simulation verification.

B. Wind turbine modelling

According to aerodynamics principle, output power characteristic of wind turbine is described by equation (4) considering the main components of a wind turbine for modelling purposes consist of the turbine rotor, a shaft and gearbox unit, an electric generator, and a control system.

$$P_W = \frac{1}{2} \rho A C_p V^3 \tag{4}$$

where P_W is power generated by the wind turbine W , ρ is density of gas in the atmosphere (kg/m^3), A is cross-sectional area of a wind turbine blade m^2 , V is wind velocity (m/sec), and C_p is the wind turbine energy conversion coefficient.

The wind turbine is normally characterized by its C_p -TSR characteristic, where TSR is the tip speed ratio and is given by equation (5),

$$TSR = \frac{\omega_m R}{V} \tag{5}$$

Where R and ω_m are the turbine radius and mechanical angular speed respectively. The wind turbine based on PMSG is used for Simulink model as shown in Figure-5.

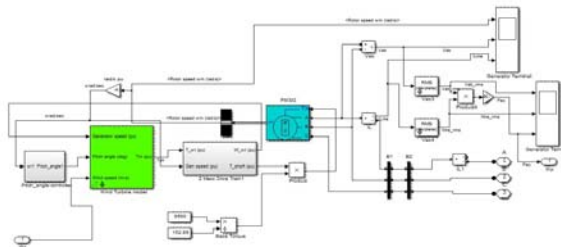

Figure-5. Simulink model of Wind Turbine.

Wind speed is the most critical factor in wind power generation. This simulated output of the phase sinusoidal voltage and current waves and Rotor Speed is shown in Figure-6.

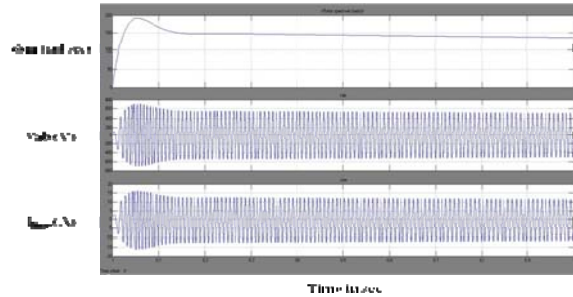

Figure-6. Simulated output Voltage (V_{ab}), Current (I_{ab}) and Rotor speed.

The output of the generator is connected to a three-phase diode bridge converter which provides a rectified power of the generator to feed the dc-dc boost converter of the wind system.

C. Lithium-ion battery modelling

Among different battery technologies, Li-ion batteries represent a suitable option for hybrid energy storage systems due to their high energy density and efficiency, light weight, and good life cycle. The generic Li-ion battery model is used. The battery state of charge (SOC) is an indication of the energy reserve and is expressed by equation (6)

$$SOC = 100 \left(1 - \frac{\int i_b dt}{Q} \right) \tag{6}$$

where i_b is the battery current, and Q is the battery capacity.

Equation (7) is the discharge equation and the charge equation of the lithium-ion battery is given by (8),

$$V_b(t+i) = E_0 - K \frac{Q}{Q - it} i^* - K \frac{Q}{Q - it} it + A \exp(-B \cdot it) \tag{7}$$

$$V_b(t+i) = E_0 - K \frac{Q}{it + 0.1Q} i^* - K \frac{Q}{Q - it} it + A \exp(-B \cdot it) \tag{8}$$

where E_0 is initial voltage (V), K is polarization resistance (Ω), i^* is low-frequency dynamic current (A), i is battery current (A), it is the battery extraction capacity (Ah), Q is maximum battery capacity (Ah), A is exponential voltage (V), B is exponential capacity (Ah)⁻¹.

Battery is simulated with constant discharge of 5 A for validation and observation of SOC variation. The results are shown in Figure-7. The battery voltage is easy to measure and implement in the circuit. From the simulated results, we can see the nonlinearity between voltage and SOC of the Li-ion battery. Therefore, the SOC



parameter of batteries has been selected as the design factor instead of battery voltage in this paper.

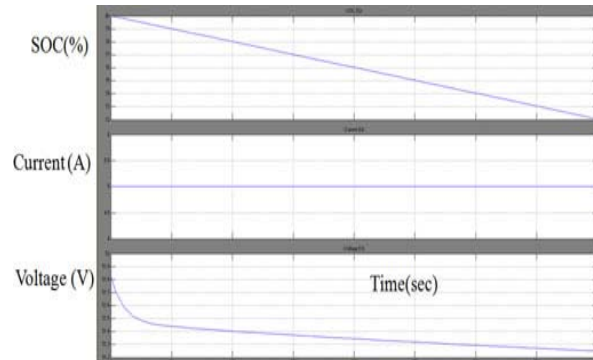

Figure-7. Simulation results with constant discharge of 5 A.

4. CHARGING AND DISCHARGING CONTROL STRATEGIES

In general, to charge and discharge the battery frequently will shorten its life time, and it also should be avoided to overcharge or insufficiently charge the battery. The wind speed is always unstable naturally. With such a renewable energy generation system, the problem is when and how the battery should be charged to provide the best energy efficiency and to prolong the life time. If the output electrical power is excessive for the consumption of the loads, the surplus is provided to charge the battery. It is extremely difficult to determine whether the battery should be charged or to prevent it from being over or insufficiently charged based on certain traditional mathematical models, so systems based on empirical rules may be more effective. We employ fuzzy control strategy to solve this problem that will be discussed in detail in the following sections.

A. Fuzzy control

Fuzzy theory was first proposed in 1965 by Lotfi. Zadeh, an American scholar of automatic control, as a tool of quantitative expression for concepts that could not be clearly defined. A fuzzy control system is based on fuzzy-logic thinking in the design of how a controller works. The so-called fuzzy logic is to establish a buffer zone between the traditional zero and one, with logic segments of none-zero and none-one possible. It allows a wider and more flexible space in logic deduction for the expression of conceptual ideas and experience. A fuzzy controller differs from a traditional controller in that it employs a set of qualitative rules defined by semantic descriptions. Fuzzy control theory is designed for the hybrid system to achieve the optimization of the system. The design criterion requires that both the photovoltaic device and the wind turbine are supplied by a maximum power point tracker to maintain the maximum operating point. The difference between actual load and total generated power is taken into account for Li-ion battery in charge and

discharge modes. The life cycle and SOC of the battery are in direct proportion. To improve the life of the Li-ion battery, we can control and maintain the SOC of battery with fuzzy control. The fuzzy controller is applied in the proposed hybrid power supply system, as shown in Figure-8.

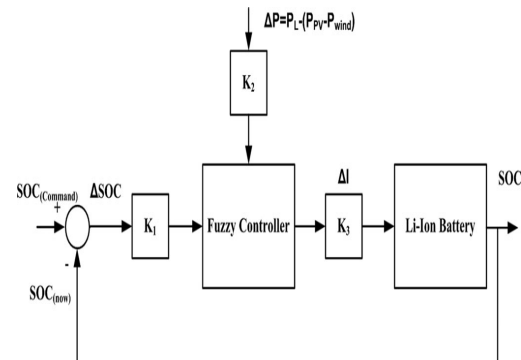

Figure-8. Block diagram of fuzzy control to maintain the desired SOC of the battery.

To obtain the desired SOC value, the fuzzy controller is designed to be in charging mode or discharging mode for the proposed hybrid system. The input variables of the fuzzy control are ΔSOC and ΔP and output variable is ΔI .

B. Design of fuzzy controller

The definition of input and output variables are listed as follows:

$$\Delta SOC = SOC_{\text{Command}} - SOC_{\text{now}} \quad (9)$$

$$\Delta P = P_L - (P + P_{PV}) \quad (10)$$

The power difference ΔP is between required power and the total generated power of the hybrid system. The generated power comes from solar power P_{pv} , wind turbine P_{wind} and power load PL for the proposed system. The input and output membership functions of fuzzy control contain five grades: NB (negative big), NS (negative small), ZO (zero), PS (positive small), and PB (positive big), as shown in Figs. 9 and 10. By input scaling factors K_1 and K_2 , we can determine the membership grade and substitute it into the fuzzy control rules to obtain the output current for charge and discharge variance ΔI of the Li-ion battery. If the ΔP is negative, it means that the renewable energy does not provide enough energy to the load. Thus, the battery must operate in charging mode; if the ΔSOC is negative, it means that the SOC of the battery is greater than the demand SOC. Thus, the battery must operate in discharge mode.



www.arpnjournals.com

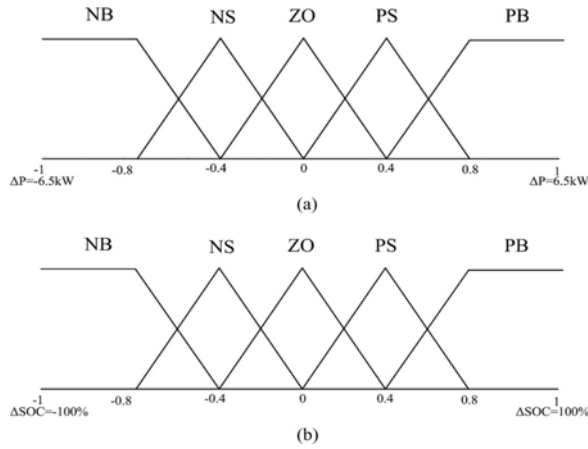

Figure-9. Input membership functions of variables: (a) ΔP and (b) ΔSOC .

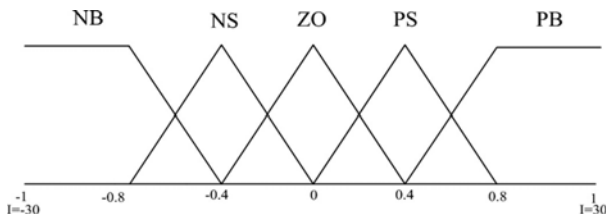

Figure-10. Output membership function of variable ΔI .

There are several methods to design a fuzzy controller. The design of fuzzy controller involves formation of membership function and rule base [8, 9]. Here, we have taken the rule base proposed by Mamdani for the simulation of the Fuzzy controller. These rules are shown in Table-1.

Table-1. Fuzzy control rules.

ΔI		ΔP				
		NB	NS	ZO	PS	PB
ΔSOC	NB	PB	PB	PB	PB	PB
	NS	PB	PB	PS	PS	PB
	ZO	ZO	ZO	ZO	PS	PB
	PS	NS	NS	NS	NS	PB
	PB	NB	NB	NB	NB	PB

For example, the output variable ΔI is PB (the degree of discharging current is large) when the input variable ΔP is NB and input variable ΔSOC is NS (greater than the SOC command and the membership degree is small). However, the output variable ΔI is NS (the degree of charging current is small) when the input variable ΔP is NB (the amount of electricity to sell is large) and input variable ΔSOC is PS (smaller than the SOC command and the membership degree is small).

5. DISCUSSIONS AND RESULT ANALYSIS

The dynamic model of the proposed hybrid system using MATLAB simulink is shown in Figure-11.

Where the system consists of a 5 kW solar module, a 1.5 kW wind turbine module, a 1.5 kW Li-ion battery module, and a 6.5 kW load.

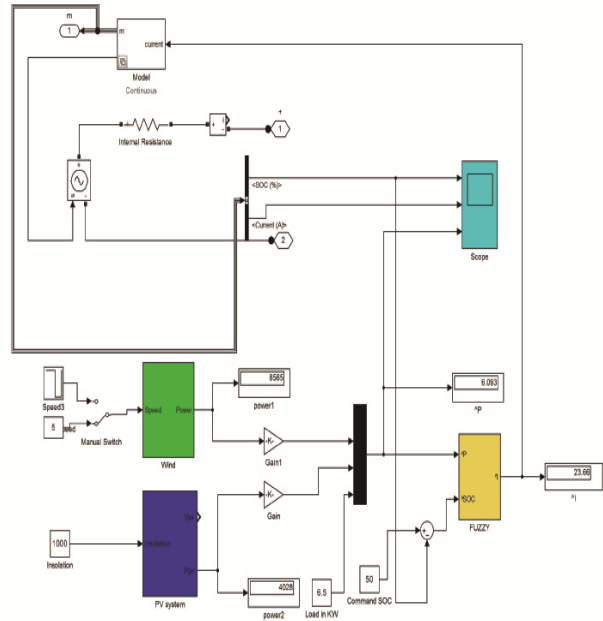

Figure-11. Dynamic model of the hybrid system using MATLAB simulink.

A. Fuzzy controller

This example verifies the accuracy of the proposed system with fuzzy controller that can maintain the SOC of the battery at a certain level whether initial value of the SOC is low or high. The Simulink model of Fuzzy Controller is shown in Figure-12.

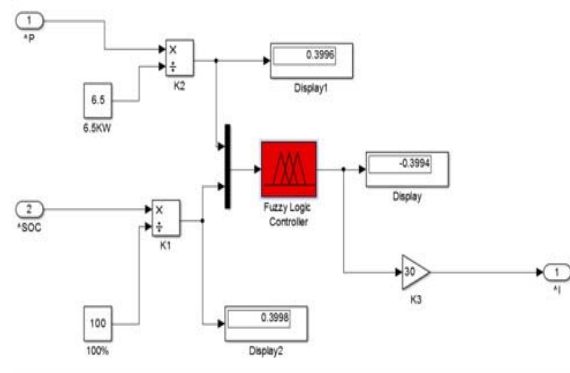

Figure-12. Simulink model of fuzzy controller.

As shown in Figure-13, the fuzzy controller Li-ion battery SOC is maintained at 50% with an initial value of 10%. As shown in Figure-12, the fuzzy controller Li-ion battery SOC is maintained at 50% with an initial value of 90%.

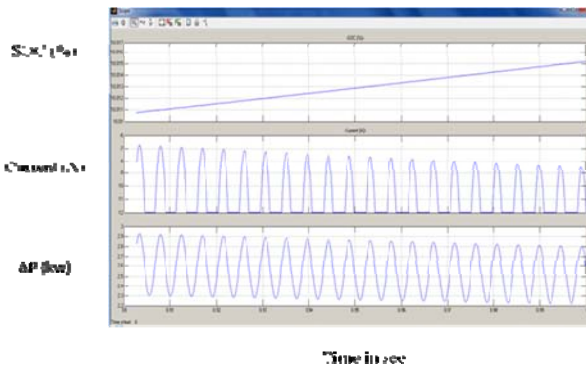

Figure-13. Simulation results with initial battery SOC at 10%.

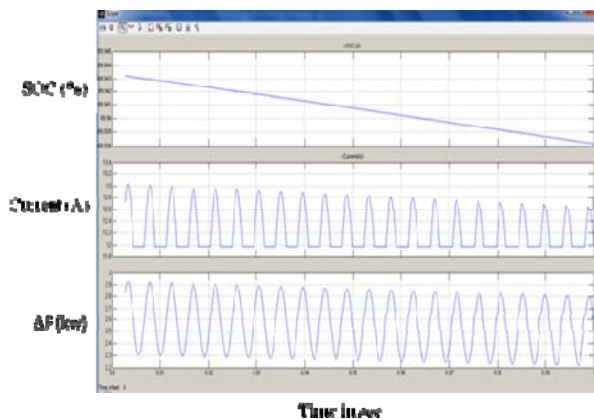

Figure-14. Simulation results with initial battery SOC at 90%.

B. Comparison with pi controller

The proposed hybrid system has been developed by using PI controller and compares the simulated results with Fuzzy Logic Control for performance validation. The PI controller Li-ion battery SOC is maintained at 50% with an initial value of 90% as shown in Figure-15.

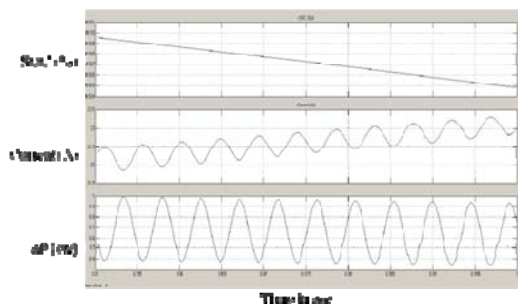

Figure-15. Simulation results of PI controller.

Through simulation work, the proposed hybrid energy system with using the FLC is compared to that with using the conventional PI controller. Where, the

obtained simulation results indicate that the response of the load power in case of using the FLC is better and faster than that obtained in case of using the PI controller at all load conditions. Table-II shows that comparison of Fuzzy and PI control for the hybrid system. This shows that the maximum overshoot and settling time values of the FLC were much better than those of the PI controller.

6. CONCLUSIONS

This paper presents the modelling, analysis, and design of fuzzy control to achieve optimization of a Battery management system for a Wind/ Solar hybrid system. According to the variation of the wind speed, solar isolation and the load demand, the fuzzy logic controller used to works effectively by turning on and off the batteries. Simulation results were obtained by developing a detailed dynamic hybrid system model. From the simulation results, the system achieves power equilibrium, and the battery SOC maintains the desired value for extension of battery life. The control process of the battery charging and discharging is non-linear, time-varying with time delays. It is a multiple variable control problem with unexpected external disturbances. Many parameters such as the charging rate, the permitted maximum charging current, the internal resistor, the port voltage, the temperature and moisture, *etc.* keep changing during the charging and discharging process can't be directly obtained, so it is difficult to achieve the optimal operation performance by using traditional control methods. A fuzzy control unit for battery charging and discharging used in a renewable energy generation system is developed. Simulation results based on fuzzy strategies show that the control unit has satisfied performance in a laboratory environment.

7. REFERENCES

- [1] P. Chiradeja and R. Ramakumar. 2004. An approach to quantify the technical benefits of distributed generation. *IEEE Trans. Energy Convers*, vol. 19, no. 4, pp. 764–773, Dec.
- [2] M. H. Nehrir, C. Wang, K. Strunz, H. Aki, R. Ramakumar, J. Bing, Z. Miao, and Z. Salameh. 2011. A review of hybrid renewable/alternative energy systems for electric power generation: Configurations, control, and applications. *IEEE Trans. Sustain. Energy*, vol. 2, no. 4, pp. 392–403, October.
- [3] Jeroen Tant, Student Member, Frederik Geth, Daan Six, and Peter Tant. 2013. Multiobjective Battery Storage to Improve PV Integration in Residential Distribution Grids" *IEEE Trans. On Sustain Energy*, Vol. 4, No. 1, January.
- [4] Yong Yin, Xing Luo, Shen Guo, Zude Zhou and Jihong Wang. 2008. A Battery Charging Control



www.arpnjournals.com

Strategy for Renewable Energy Generation Systems.
Proceedings of the World Congress on Engineering.

- [5] Yu-Kai Chen, Yung-Chun Wu, Chau-Chung Song, and Yu-Syun Chen. 2013. Design and Implementation of Energy Management System With Fuzzy Control for DC Microgrid Systems” IEEE Transactions On Power Electronics, Vol. 28, No. 4, April.
- [6] P. Rong. and M. Pedram. 2006. Dynamic Lithium-Ion Battery Model for System Simulation. IEEE Transactions on Very Large Scale Integration Systems, Vol. 14.
- [7] K. A. Smith. 2006 Electrochemical Modeling, Estimation and Control of Lithium-ion Batteries. Department of Mechanical Engineering, The Pennsylvania State University, USA.
- [8] Onur Ozdal Meng I. and Ismail Hakkı Altas. 2012. Fuzzy Logic control of wind/Battery renewable energy production system. Turk J Elec Eng & Comp Sci, Vol.20, No.2.
- [9] S. N. Sivanandham. and S. N. Deepa. 2007. Principals of Soft Computing. Wiley India Ltd.