



INTAKE ANALYSIS ON FOUR-STROKE ENGINE USING CFD

A. M. Mohd Shafie¹, Musthafah M. T.¹, M. S. Ali¹, Rosli A. Bakar² and Mohamed Arifin Y.¹

¹Faculty of Mechanical Engineering, Universiti Teknikal Malaysia Melaka, Durian Tunggal Melaka, Malaysia

²Faculty of Mechanical Engineering, Universiti Malaysia Pahang, Pekan, Pahang, Malaysia

E-Mail: amientk@gmail.com

ABSTRACT

Flow patterns are vital to ensure that the engine can produce high performance with the presence of swirl and tumble inside the cylinder. In this paper, the simulation of air is simulated in the software to predict the flow pattern using the steady state pressure based solver at two different planes in the engine domain. The domain used for the simulation is based on the actual engine parameters. Using the commercial CFD solver ANSYS FLUENT, the CFD simulation is run under five different piston positions and seven different engine speeds. Note that in this simulation, only intake strokes are simulated. The results show the velocity of the flow is high during the sweeps the intake stroke takes place. This situation is believed to produce more swirls and tumble during the compression, hence enhancing the burning rate in an entire region of the clearance volume. The result shows that both for plane A-A and plane B-B, the highest velocity vector occurs when the engine speed at 4500 rpm with piston position at 45 degree. This will initiate to the production of tumble and swirl in the engine cylinder.

Keywords: CFD, fluent, in-cylinder flow, intake flow, meshing.

INTRODUCTION

Engines are used to propel the vehicle by converting the chemical energy to mechanical motion. Reciprocating Engine with four-stroke cycle consists of the intake stroke, compression stroke, expansion stroke and exhaust stroke. At the stages of intake and compression stroke, it is the most influential part to dictate the flow pattern and structure of air entering and exiting the swept volume [1]. Air flow for the internal combustion engine is generally in turbulent flow as the speed of the internal combustion engines is high [2]. This turbulent flow is excluded when the flow goes through a crevice volume as it will diminish the turbulence near the wall. The domain used in the simulation is based on the engine used by [3] for engine dynamometer with 3.36 kW of power. Typically, turbulence kinetic energy and turbulence kinematic viscosity are the benchmark to measure the turbulence with compressible flow in the cylinder [2]. CFD is the most promising tool to foretell the flow structure and pattern of the air inside the engine cylinder and provides the details of the tumble and swirl in the cylinder. Furthermore, the velocity profile as well as pressure within the domain for given boundary condition can be obtained completely [4, 5]. Flow development and decay in the cylinder is usually analyzed with stable turbulence models such k-epsilon and RNG in the CFD. Fontanesi, Cicalese and Severi [4] stated that instead of using the simple model, it is recommended to use more refined model such as Large Eddy Simulation (LES) or Detached Eddy Simulation (DES). On the other hand, for a better RANS modeling, it is recommended to use Reynolds Stress and K-omega SST with enough resolution for near wall flow. [4] stated that in recent years, the Large Eddy Simulation (LES) or Detached Eddy Simulation (DES) was used in application of flows in the internal combustion engine. Flow in the cylinder of the engine inherently decisive for the combustion performance of the engine [6].

During the intake stroke and compression stroke, creating a vortical flow motion which is swirling and/or tumble is indispensable not only to have a fast burning rate but also high mixing process with the air inside the engine cylinder [1]. It is due to single properly defined vortical structure is more stable than other large scale in-cylinder flow [7, 8]. Swirl is air movement in the cylinder about the cylinder axis while tumble is a movement of air in direction of upside to downside or conversely, that the circles are at the perpendicular axis of the engine cylinder. Hence, during combustion it generates higher turbulence and faster flame-front propagation [6]. Besides, suitable value of swirl will improve the fuel efficiency hence the duration of the combustion can be abbreviated. [2] claimed that 4% from burning time loss is one of the primary loss in spark ignition engine which its occurrence resulting from finite time of combustion. Increasing the degree of swirl leads to increase of the turbulence intensity inside the cylinder and this situation can eliminate the loss of burning time. Higher turbulence intensity produces more stable ignition process and faster flame propagation, particularly in lean-burn combustion.

SIMULATION SETUP

Computational Domain

The domain was created according to the actual engine as illustrated in Figure-1 with the specifications shown in the Table 1 which is then drawn in CAD Software, CATIA P3 V5R20. A comprehensive study was conducted by comparing the physical model with computational model in order to minimize the modeling error with fewer number of iterations [5]. In the Figure-1 also shows the domain that is imported to the ANSYS workbench. In order to simulate the domain, mesh was generated in the ANSYS-Mesh to divide the domain into a small size. Automatic mesh generation was used for the entire domain. Quality of mesh is important to the



accuracy of the result. Figure-2 (a) shows the complete cycle of a four-stroke engine. The position of the engine is varied with 9°, 18°, 27°, 36°, and 45° after top dead center. Furthermore, the simulation runs at various speeds with increment of 500 rpm starting at 1500 rpm and ending at 4500 rpm. Note that the shape of the cylinder head is flat in shape [9].

Table-1. Specification of engine used.

Engine type	Robin EY20-3, 0.5 HP
Max. Power (HP/rpm)	5/4000
Max. Torque (kgm/rpm)	0.96/2800
Bore × Stroke (mm)	67.4 × 52
Intake air	Naturally aspirated
Type of Piston Head	Flat
Compression Ratio	6.3
Inlet Diameter (mm)	26
Outlet Diameter (mm)	21

The mesh quality needs to comply with mesh metric of maximum skewness below 0.98 and the maximum orthogonal quality with approach to one. Mesh skewness is vital to control because it will affect not only the convergence, but also the result of the simulation. The domain shown in Figure-2 (b) illustrates the cut-view with the piston located 45° after top dead center and it was in a good quality of mesh with maximum skewness of 0.968 and orthogonality of 0.996. The elements of the domain are 148852 of tetrahedron elements.

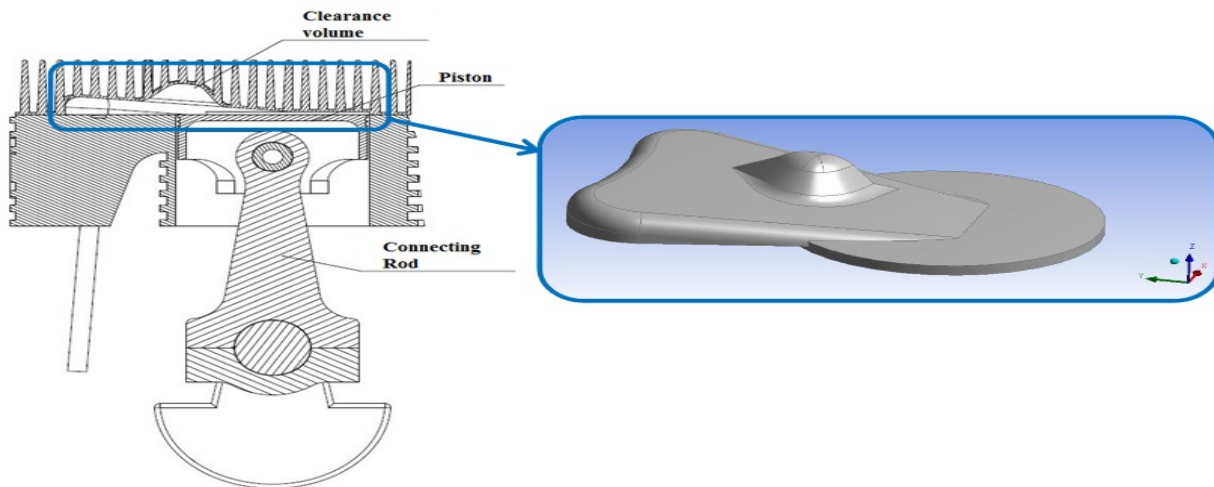

Figure-1. Clearance volume of the in-cylinder engine and imported domain in ANSYS workbench.

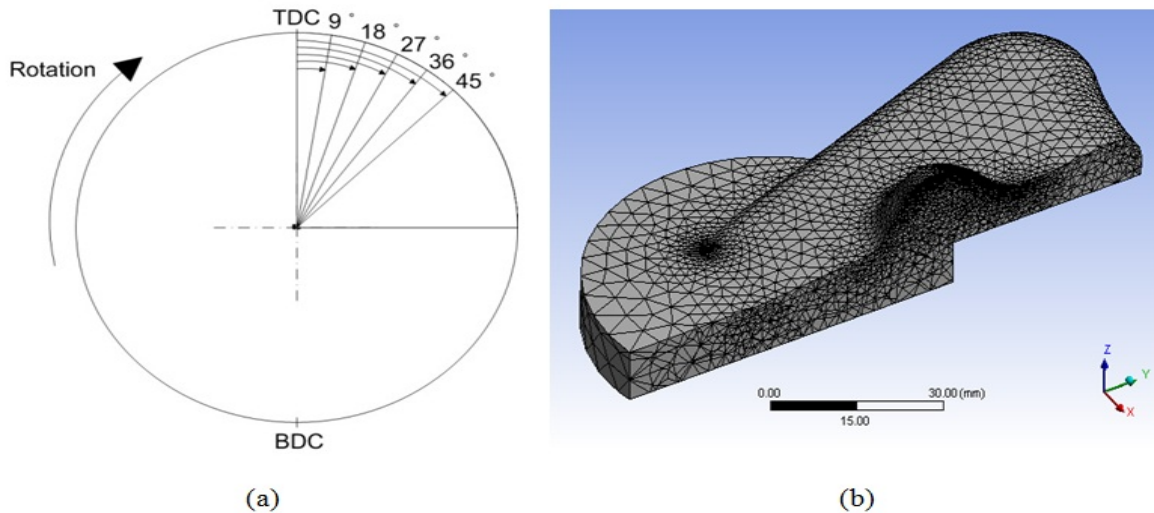

Figure-2. (a) Complete cycle; (b) Cut-view of the clearance volume of the engine.



Numerical Strategy

The compressible Navier-Stoke equations of momentum, continuity and energy were used to solve the flow simulation in ANSYS FLUENT. The generalization of each of governing equations has the following forms, respectively: The derivation of the mass equation is known as continuity equation is based on the control volume and the equivalent differential equation is written as:

$$\frac{\partial \rho}{\partial t} + \nabla \cdot (\rho \bar{v}) = 0 \quad (1)$$

where \bar{v} is flow velocities in x , y , and z direction for three dimensional flow case and ρ is the density of fluid used in the simulation.

Momentum equation is founded from the Newton's second law of fluid motion which the body and the surface forces considered in the control volume are described as:

$$\frac{\partial (\rho v)}{\partial t} + \nabla \cdot (\rho v \times v) = -\nabla p + \nabla \cdot \tau + S_M \quad (2)$$

where v is the flow velocity, p is the static pressure, τ is the strain rate and S_M is the momentum sources acting on the fluid. These equations are also known as the Navier-Stoke equation. The energy equation used is described as:

$$\frac{\partial (\rho h_{tot})}{\partial t} + \nabla \cdot (\rho U h_{tot}) = \nabla \cdot (\lambda \nabla T) + \nabla \cdot (U \cdot \tau) + U \cdot S_M \quad (3)$$

where λ and h_{tot} represent the thermal conductivity and total enthalpy of the fluid. Eqn. (1) - Eqn. (3) were incorporated into CFD models in order to solve the simulation of the domain.

Simulation Setting

This simulation is performed in the steady state with the pressure-based solver that solves the equation of energy, momentum and continuity at initial. Model of k -epsilon of realizable with Non-equilibrium wall function is used since the model is simple and stable for the initial simulation strategy to predict the flow pattern in the cylinder [4]. The purpose of using Non-equilibrium wall function is to indicate the flow near the wall as the source of the turbulence and vorticity [5]. Pressure field is obtained using SIMPLE algorithm for pressure-velocity coupling. The discretization scheme for a convective term of momentum and energy used the second order upwind scheme while the others used the first order upwind. Only two boundary conditions considered in this case; velocity inlet and pressure outlet. The other region is prescribed as wall and assumed as no-slip and adiabatic. The velocity of the inlet is calculated from the continuity of the piston speed at various engine speeds which is at 1500 rpm, 2000rpm, 2500 rpm, 3000rpm, 3500 rpm, 4000 rpm and 4500 rpm. However, the initial gauge pressure is set as

1atm for all engine speed. The pressure outlet is set to 0.87 Pa as referred to the GT-Power software as the pressure is low when the intake process occurs.

RESULTS AND DISCUSSIONS

All of the results for the simulation are illustrated based on the planes as shown in the Figure-3 consist of Plane A-A and Plane B-B to ensure the comparison is at the similar place. Plane A-A is illustrated as a cutaway view in the clearance volume viewed from the z -direction with the same axis as the cylinder axial axis. Meanwhile Plane B-B is a cutaway viewed from x -direction. Plane A-A located at the bottom surface of the combustion chamber in order to monitor the velocity profile when air enters the cylinder. Plane B-B is placed near to the flow entering the spark plug region.

Flow in the cylinder is vital for the internal combustion engine to be more efficient. Swirl and tumble flow in the cylinder are inherently decisive for the mixture to be mixed well to form homogeneous mixture in a brief time before the combustion occurs [2]. Figure-4 shows the flow viewed from the plane A-A located at the entering region of the flow from the combustion chamber to the swept volume. The flow velocity seems to be higher when air flows through the volume which has a lower cross sectional area as can be seen in the illustration of the domain. For engine speed 4500 rpm, it is clear that the air flow velocity is higher at the left side of the wall since the inlet air located more at the left side hence producing higher velocity. It is noticeable that each of the crank angles has different values of legend in Figure-4.

However the maximum value for the legend at each crank angle is based on the local value at that position. Air flow at engine speed of 4500 rpm and crank angle of 45 degree has higher velocity produced compared to the others as the inlet velocity for this circumstance is the highest. Hence, the velocity produced at this circumstance is the highest as well.

Figure-5 shows the view of the air flow at the Plane B-B located vertically with the cylinder and near the spark plug location. At this position, the flow of air produces around the spark plug can be observed. Most of the flows at this view have higher velocity at the entrance to swept volume which is cylindrical as viewed from the Plane A-A. From Figure-5(a), it shows that at the engine speed at 4500 rpm with piston located 18 degree after top dead center develops high velocity near ignition region. This can be one of the triggers of producing a tumble at the combustion chamber [10]. Among all boundary conditions given, engine speed of 4500 rpm and crank angle of 45 degree creates highest velocity at the entrance of swept volume which is then believed to produce swirl and tumble. Hence, enhanced mixing of the fuel and air improves the engine performance [11]. High engine speed produces a high inlet air flow which helps the development of higher swirl and vice versa.

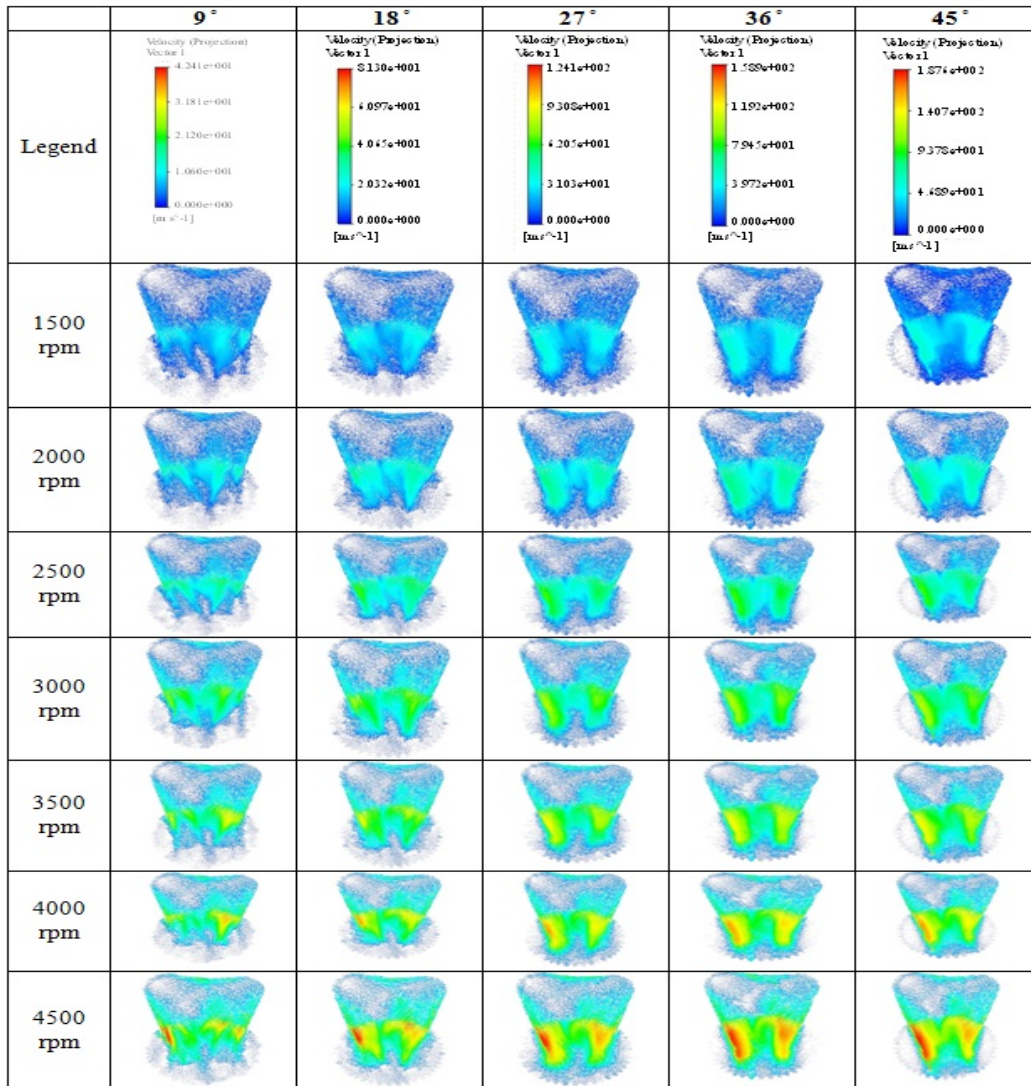
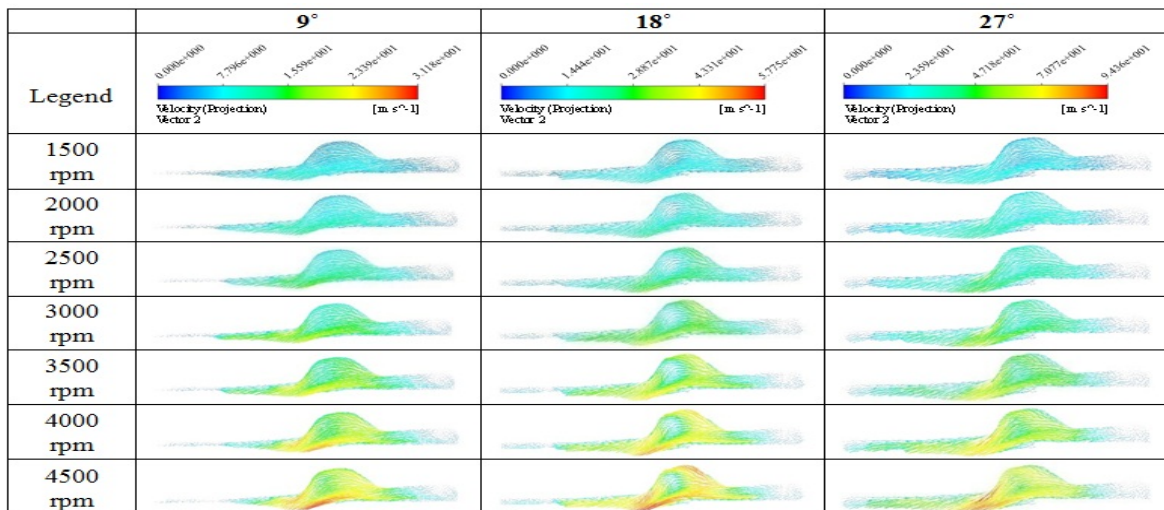
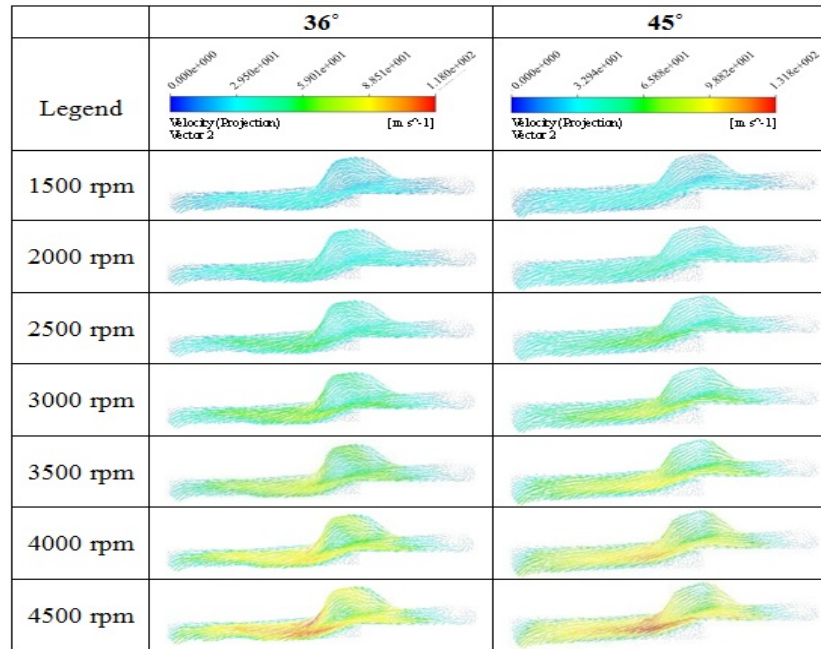

Figure-3. Flow viewed from Plane A.



(a)



(b)

Figure-4. (a) Flow viewed from Plane B-B for 9°, 18°, and 27°; (b) Flow viewed from Plane B-B for 36° and 45°.

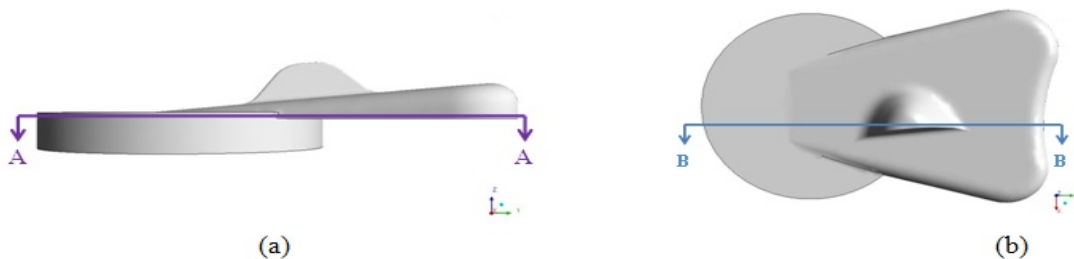

Figure-5. (a) Reference plane of cutaway A-A; (b) Reference plane of cutaway B-B.

CONCLUSIONS

This paper manifests the flow structure and pattern of air inside the swept volume for a steady state condition with desired parameters given. Presence of swirl and tumble inherently improves the combustion propagation hence increasing the performance of the engine. Result of the in-cylinder flow for the first 45 degree after top dead center shows that air flow have higher velocity when approaching the entrance of swept volume. The flow of air during the intake process dictates the tumble and swirl formation before piston moving upward to top dead center in compression process. It is foretold that the turbulence occurs at the clearance volume as the shape of squish area lead to encourage the turbulence flow for the domain. The limitation of this paper is that the simulation only simulates at the intake process and not at the compression process which can illustrate more tumble and swirl flow. For the future work, the simulation will be performed with the presence of fuel and air to observe the mixing process occurs in the clearance volume and swept volume.

ACKNOWLEDGEMENTS

The authors are grateful to Faculty of Mechanical Engineering, Universiti Teknikal Malaysia Melaka (UTeM) for financial support of short-term grant research project no. PJP/2013/FKM (9B) /SC01227. The deepest appreciation is granted to the research center of Faculty of Mechanical Engineering (GTeV, CARE) as well as Universiti Malaysia Pahang, Professor Dato' Rosli Abu Bakar for the assistance in this project.

REFERENCES

- [1] D. Ramasamy, K. Aik Soon, H. Walker-Gitano Briggs and Z.A. Zainal. 2013. Variation of Airflow Pattern through Dissimilar Valve Lift in a Spark Ignition Engine. Journal of the Chinese Institute of Engineers. Vol. 36, pp. 1083-1096.



- [2] K. Pandey and B. Roy. 2012. CFD Analysis of Intake Valve for Port Petrol Injection SI Engine. *Global Journal of Researches in Engineering*. Vol. 12.
- [3] M. Alfaiz, M.T. Musthafah, A.B. Rosli, M.S. Ali and A. Muhaimin. 2013. New Design of a Low Cost Small Engine Dynamometer for Engine Testing. In: 3rd International Conference and Exhibition on Sustainable Energy and Advanced Material. *Trans Tech Publ. Melaka*. pp. 642-647.
- [4] S. Fontanesi, G. Cicalese and E. Severi. 2013. Analysis of Turbulence Model Effect on the Characterization of the In-Cylinder Flow Field in a HSDI Diesel Engine. *SAE Technical Paper*.
- [5] V. Kumar, N. Sivagaminathan, N. Gopalakrishnan, S. Morton, M. Marine and P. Radavich. 2000. Air flow and charge motion study of engine intake port. In: *Proc. 37th National and 4th International Conference on Fluid Mechanics and Fluid Power*. Number FMFP10-CR-10. pp. 26-30.
- [6] H. Puneekar and S. Das. 2013. Numerical Simulation of Subcooled Nucleate Boiling in Cooling Jacket of IC Engine. *SAE Technical Paper*.
- [7] S. Bari and I. Saad. 2013. CFD modelling of the effect of guide vane swirl and tumble device to generate better in-cylinder air flow in a CI engine fuelled by biodiesel. *Computers & Fluids*. Vol. 84, pp. 262-269.
- [8] R. Huang, H. Yang and C.-N. Yeh. 2008. In-cylinder flows of a motored four-stroke engine with flat-crown and slightly concave-crown pistons. *Experimental Thermal and Fluid Science*. Vol. 32, pp. 1156-1167.
- [9] N.R. Abdullah, N.S. Shahrudin, R. Mamat, A. Mohd, I. Mamat and A. Zulkifli. 2013. Effects of Air Intake Pressure on the Engine Performance, Fuel Economy and Exhaust Emissions of A Small Gasoline Engine. *Journal of Mechanical Engineering and Science*. Vol. 6, pp. 949-958.
- [10] R. Devarajan, A.B. Rosli, R. Mohd Fadzil and M.N. Muhamad. 2008. Comparative Evaluation of a Two Stroke Compressed Natural Gas Mixer Design using Simulation and Experimental Techniques. In: *Proceedings of the 4th IASTED Asian Conference on Power and Energy Systems*. AsiaPES 2008. International Association of Science and Technology for Development (IASTED). pp. 606.
- [11] D. Ramasamy, Z. Zainal, R. Bakar and K. Kadirgama. 2014. Mass fraction burn comparison of compressed natural gas and gasoline. In: *Applied Mechanics and Materials*, *Trans Tech Publ.* pp. 442-446.